



# MOTION INDEX DRIVES

## PARALLEL INDEX DRIVES XP Series



# Calculations

J = moment of inertia

$$M_B = c_a \times n \frac{2\pi}{n \times t^2}$$

$$M_R = \mu \times g \times R \times m$$

$$M_{AB} = M_B + M_R + (M_{ST})^*$$

$$M_{ST} = m \times g \times R$$

$$M_{AN} = ((M_B \times c_m) + (M_{ST} \times C_v)) \times \frac{360^\circ}{n \times a}$$

$$P = \frac{M_{AN} \times f_a}{9550 \times n}$$

\*with one-sided lifting of loads

J = moment of inertia [kgm<sup>2</sup>]

M<sub>B</sub> = acceleration torque [Nm]

M<sub>R</sub> = friction torque [Nm]

M<sub>AB</sub> = indexer torque [Nm]

M<sub>ST</sub> = static torque [Nm]

M<sub>AN</sub> = drive torque [Nm]

μ = friction coefficient

g = acceleration of gravity = 9,81m/s<sup>2</sup>

R = radius

m = mass [kg]

a = switching angle [°]

t<sub>s</sub> = index time [s]

n = number of stops

i = ratio

P = drive power [kW]

n = efficiency worm gear

f<sub>a</sub> = drive speed [1/min]

MS = ACCELERATION	MS0	MS30	M250
c <sub>a</sub> = acceleration coefficient	5.53	6.41	8.01
c <sub>m</sub> = performance coefficient	0.99	0.81	0.72
c <sub>v</sub> = speed coefficient	1.76	1.43	1.27

Sorting and Isolation

$$M_{AB} = M_B + M_{ST}$$

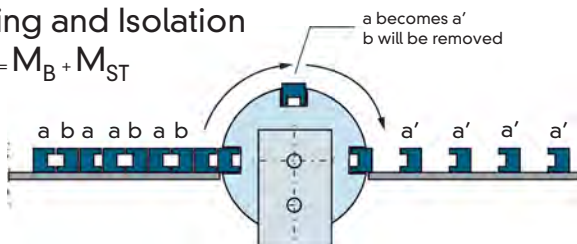

# Application examples

Direct driven belt/chain

$$M_{AB} = M_B + M_B$$

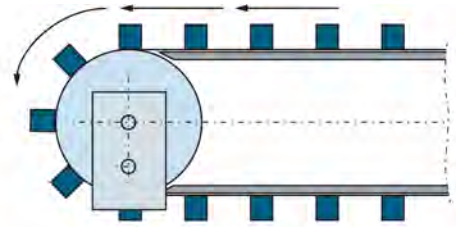

Indirect driven belt/chain

$$M_{AB} = \frac{M_B}{i^2} + \frac{M_R}{i}$$

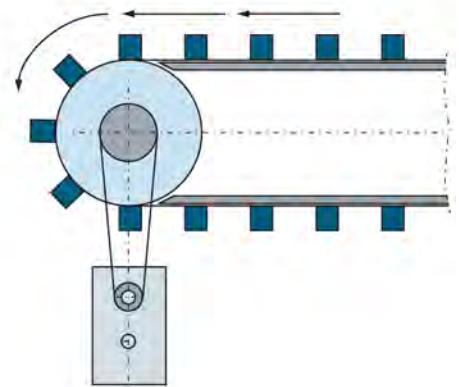

Arm

$$M_{AB} = M_B + M_{ST}$$

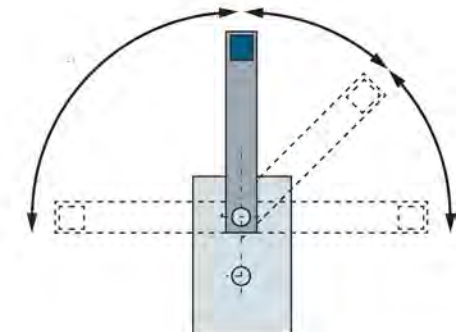

Transducer of rotations in horizontal movement

$$M_{AB} = M_B + M_R$$

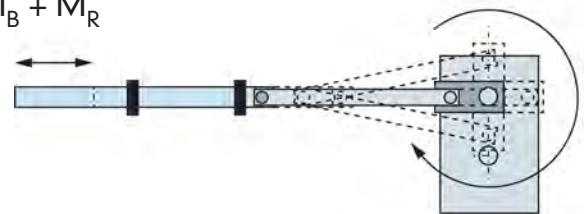

Rotate part

$$M_{AB} = M_B$$



# Configuration of all parallel drives

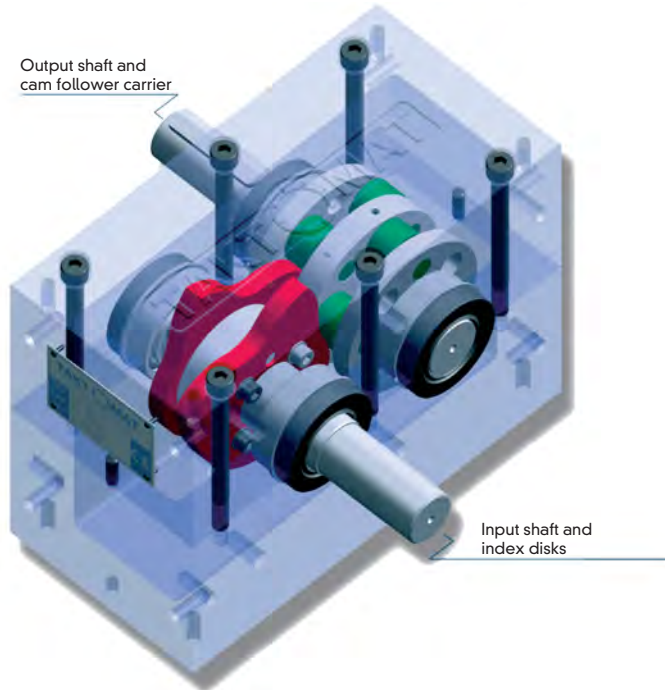

## XP030

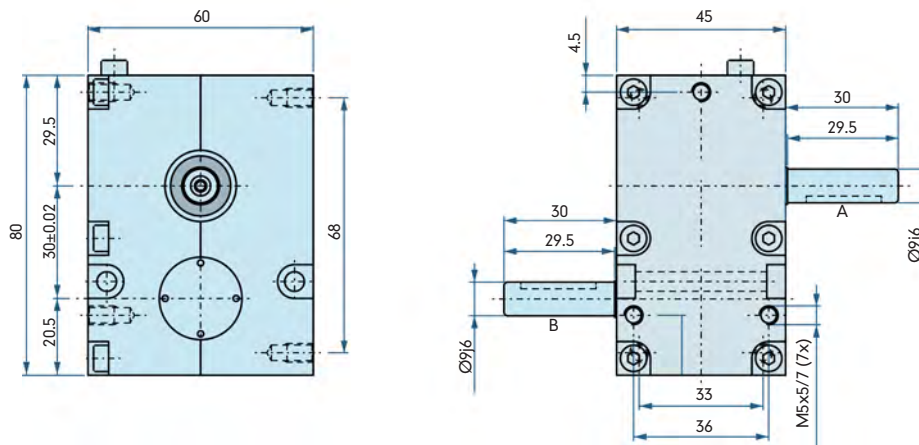

## Dimensions

The measurements shown here illustrate the standard unit. We will gladly customize the housing and or shaft(s) to suit your needs. The drive shaft as well as the output shaft are available as double sided shafts with and without a keyway. If you would like to add additional holes into the housing yourself, please contact us for possible drilling depths.

A = Drive shaft

B = Output shaft



The dimensions for the gearmotor may change based on the gearmotor size and options required for the application.

# XP030 Load Table

Angle on Output Shaft [°]	Number of Stops n	Index Angle [°]	Acceleration Form MS	Indexer Torque $M_{AB}$ [Nm]			Moment of Inertia J [kgm <sup>2</sup> ]			Mechanical Index Time $t_s$ [S]		
				n=50	n=100	n=200	n=50	n=100	n=200	n=50	n=100	n=200
360°	1	330	MS30	13	10	9	0.25	0.05	0.01	1.1	0.55	0.28
		300	MS50	13	10	9	0.26	0.05	0.01	1	0.5	0.25
180°	2	270	MS0	13	11	9	0.42	0.09	0.02	0.9	0.45	0.23
		210	MS30	13	10	8	0.29	0.06	0.01	0.7	0.35	0.18
		150	MS50	13	10	8	0.1	0.02	0	0.5	0.25	0.13
120°	3	270	MS0	17	14	12	0.95	0.2	0.04	0.9	0.45	0.23
		210	MS30	17	14	12	0.5	0.1	0.02	0.7	0.32	0.18
		150	MS30	16	13	11	0.24	0.05	0.01	0.5	0.25	0.13
		120	MS30	16	13	11	0.15	0.03	0.01	0.4	0.2	0.1
90°	4	270	MS0	13	13	11	0.97	0.24	0.05	0.9	0.45	0.23
		210	MS0	13	13	11	0.59	0.15	0.03	0.7	0.35	0.18
		150	MS30	12	12	10	0.24	0.06	0.01	0.5	0.25	0.13
		90	MS30	11	11	9	0.08	0.02	0	0.3	0.15	0.08
72°	5	270	MS0	13	13	11	1.21	0.3	0.06	0.9	0.45	0.23
		210	MS0	13	13	11	0.73	0.18	0.04	0.7	0.35	0.18
		150	MS30	12	12	10	0.3	0.07	0.02	0.5	0.25	0.13
		90	MS30	11	11	9	0.1	0.02	0.01	0.3	0.15	0.08
60°	6 <sup>1)</sup>	270	MS0	16	16	12	1.79	0.45	0.08	0.9	0.45	0.23
		240	MS0	16	16	12	1.42	0.35	0.07	0.8	0.4	0.2
		180	MS30	15	15	11	0.64	0.16	0.03	0.6	0.3	0.15
		120	MS30	13	13	10	0.25	0.06	0.01	0.4	0.2	0.1
45°	8 <sup>1)</sup>	270	MS0	12	12	11	1.79	0.45	0.1	0.9	0.45	0.23
		240	MS0	12	12	11	1.42	0.35	0.08	0.8	0.4	0.2
		180	MS30	12	12	11	0.69	0.17	0.04	0.6	0.3	0.15
		120	MS30	11	11	10	0.28	0.07	0.02	0.4	0.2	0.1

<sup>1)</sup> Parallel drives with stop numbers 6, 8 and 10 are designed as a double index, i.e. with each full rotation of the drive shaft, two indexes occur in the output.

<sup>2)</sup> Parallel drives with 12 stops are designed as a four step index, i.e. with each full rotation of the drive shaft, four indexes occur in the output.

<sup>3)</sup> The additional load occurring with chains and belts due to friction is not taken into consideration here and must be calculated separately.

## Main Dimensions

Shaft distance [mm]	30
Weight without drive [kg]	0.7
Index angle [°]	see Load Table
(other index angles upon request)	
Number of stops	1,2,3,4,5,6,8
(other numbers of stops upon request)	
Rotating direction	right, left, oscillating
Mounting position	ANY

## Capacities

Max. Output torque	see Load Table
Input Shaft	
Load rating dynamic [kN]	1.38
Load rating static [kN]	0.58
Output Shaft	
Load rating dynamic [kN]	1.38

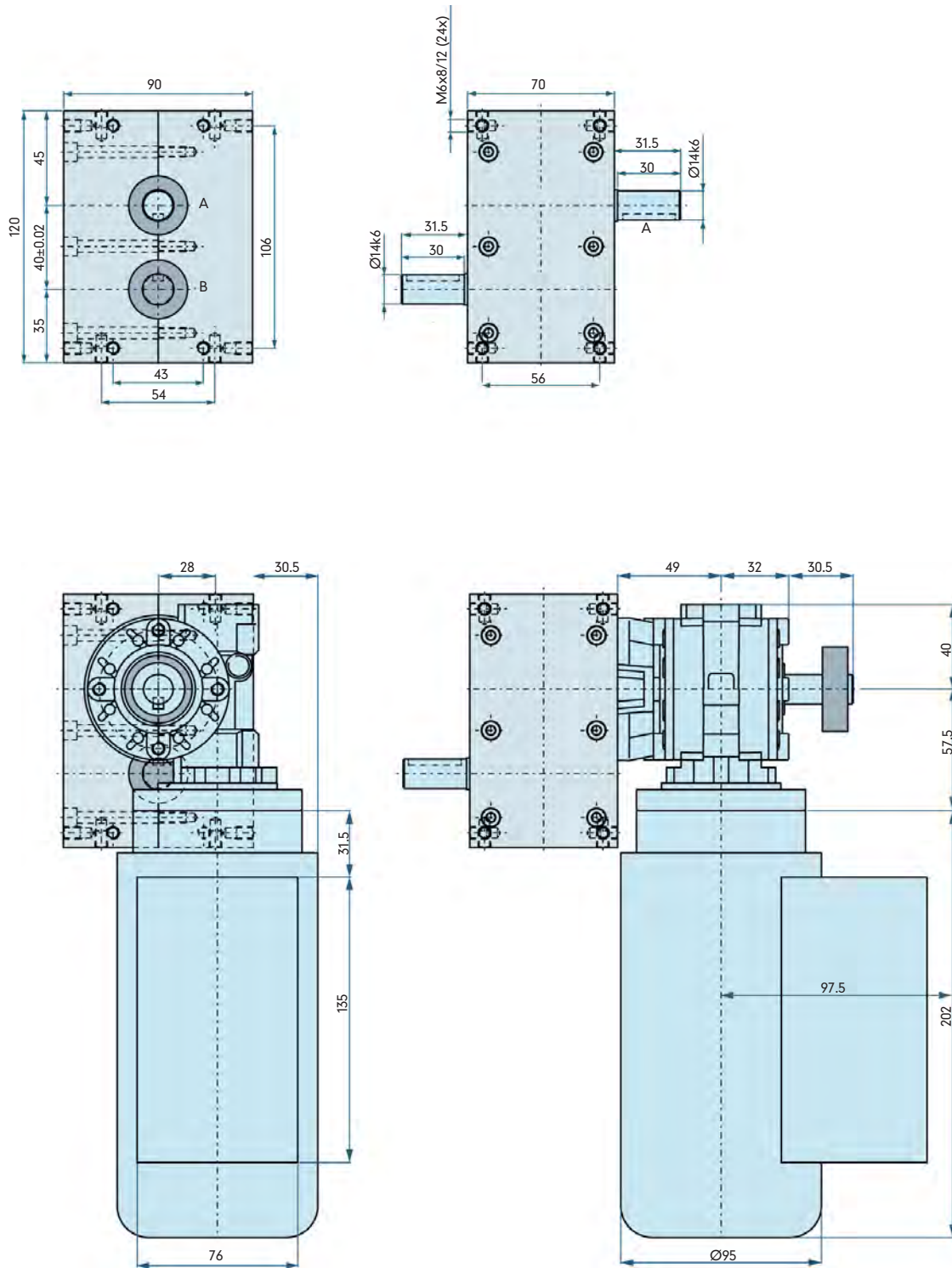

## XP040 Dimensions

The measurements shown here illustrate the standard unit. We will gladly customize the housing and or shaft(s) to suit your needs. The drive shaft as well as the output shaft are available as double sided shafts with and without keyways. If you would like to add additional holes into the housing yourself, please contact us for possible drilling depths.

A = Drive Shaft

B = Output Shaft



The dimensions for the gearmotor may change based on the gearmotor size and options required for the application.

# XP040 Load Table

Angle on Output Shaft [°]	Number of Stops n	Index Angle [°]	Acceleration Form MS	Indexer Torque $M_{AB}$ [Nm]			Moment of Inertia J [kgm <sup>2</sup> ]			Mechanical Index Time $t_s$ [S]		
				n=50	n=100	n=200	n=50	n=100	n=200	n=50	n=100	n=200
360°	1	330	MS30	29	25	21	0.56	0.12	0.03	1.1	0.55	0.28
		300	MS50	28	24	20	0.56	0.12	0.02	1	0.5	0.25
180°	2	270	MS0	32	27	24	1.03	0.22	0.05	0.9	0.45	0.23
		210	MS30	26	24	21	0.59	0.14	0.03	0.7	0.35	0.18
		150	MS50	25	23	20	0.2	0.05	0.01	0.5	0.25	0.13
120°	3	270	MS0	39	33	26	2.18	0.46	0.09	0.9	0.45	0.23
		210	MS30	29	33	26	1.14	0.24	0.05	0.7	0.35	0.18
		150	MS30	33	27	23	0.49	0.1	0.02	0.5	0.25	0.13
		120	MS30	30	25	20	0.29	0.06	0.01	0.4	0.2	0.1
90°	4	270	MS0	36	30	24	2.69	0.56	0.11	0.9	0.45	0.23
		210	MS0	36	30	24	1.63	0.34	0.07	0.7	0.35	0.18
		150	MS30	35	29	23	0.7	0.14	0.03	0.5	0.25	0.13
		90	MS30	32	28	21	0.23	0.05	0.01	0.3	0.15	0.08
72°	5	270	MS0	36	30	24	3.36	0.7	0.14	0.9	0.45	0.23
		210	MS0	36	30	24	2.03	0.42	0.08	0.7	0.35	0.18
		150	MS30	35	29	23	0.87	0.18	0.04	0.5	0.25	0.13
		90	MS30	32	28	21	0.29	0.06	0.01	0.3	0.15	0.08
60°	6 <sup>1)</sup>	270	MS0	42	34	28	4.7	0.95	0.2	0.9	0.45	0.23
		240	MS0	42	34	28	3.72	0.75	0.15	0.8	0.4	0.2
		180	MS30	40	32	25	1.72	0.34	0.07	0.6	0.3	0.15
		120	MS30	36	29	22	0.69	0.14	0.03	0.4	0.2	0.1
45°	8 <sup>1)</sup>	270	MS0	42	34	28	6.27	1.27	0.26	0.9	0.45	0.23
		240	MS0	42	34	28	4.95	1	0.21	0.8	0.4	0.2
		180	MS30	40	32	25	2.29	0.46	0.09	0.6	0.3	0.15
		120	MS30	36	29	22	0.92	0.18	0.03	0.4	0.2	0.1
36°	10 <sup>1)</sup>	270	MS0	42	34	28	7.84	1.59	0.33	0.9	0.45	0.23
		240	MS0	42	34	28	6.19	1.25	0.26	0.8	0.4	0.2
		180	MS30	40	32	25	2.86	0.57	0.11	0.6	0.3	0.15
		120	MS30	36	29	22	1.14	0.23	0.04	0.4	0.2	0.1

<sup>1)</sup> Parallel drives with stop numbers 6, 8 and 10 are designed as a double index, i.e. with each full rotation of the drive shaft, two indexes occur in the output.

<sup>2)</sup> Parallel drives with 12 stops are designed as a four step index, i.e. with each full rotation of the drive shaft, four indexes occur in the output.

<sup>3)</sup> The additional load occurring with chains and belts due to friction is not taken into consideration here and must be calculated separately.

## Main Dimensions

Shaft distance [mm]	40
Weight without drive [kg]	2
Index angle [°]	see Load Table
(other index angles upon request)	
Number of stops	1,2,3,4,5,6,8,10
(other numbers of stops upon request)	
Rotating direction	right, left, oscillating
Mounting position	ANY

## Capacities

Max. Output torque	See Load Table
Input Shaft	
Load rating dynamic [kN]	4.36
Load rating static [kN]	2.24
Output Shaft	
Load rating dynamic [kN]	4.36
Load rating static [kN]	2.24

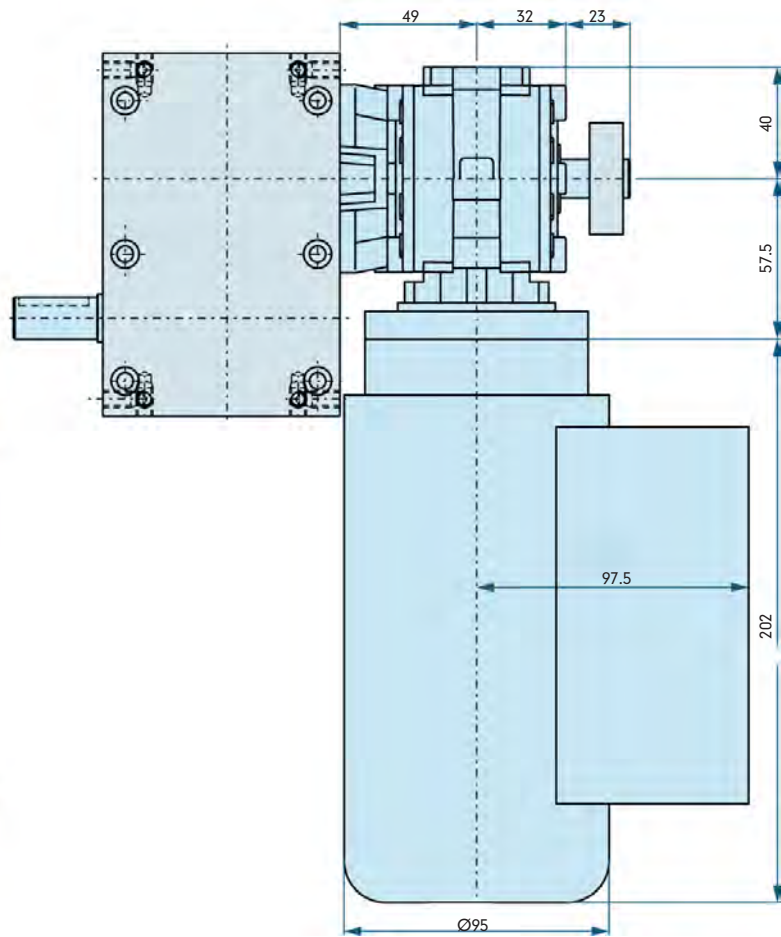
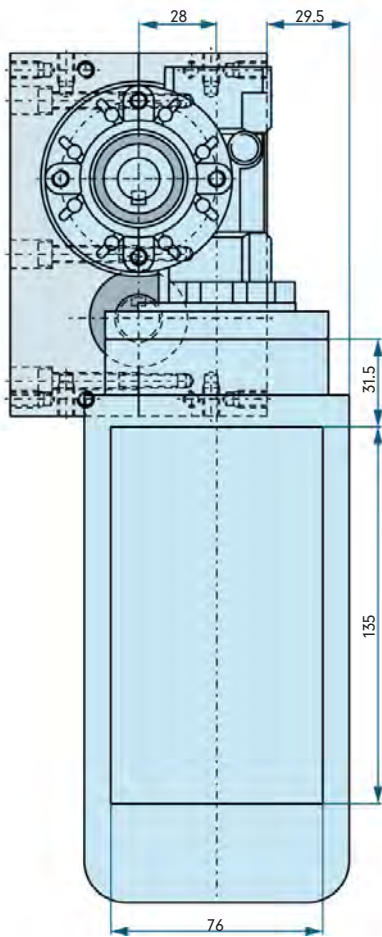
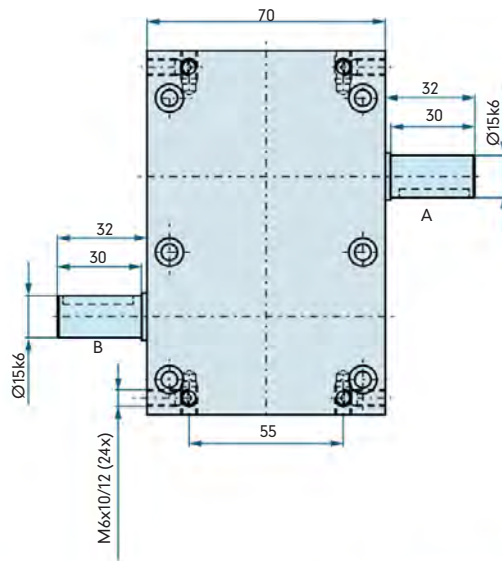
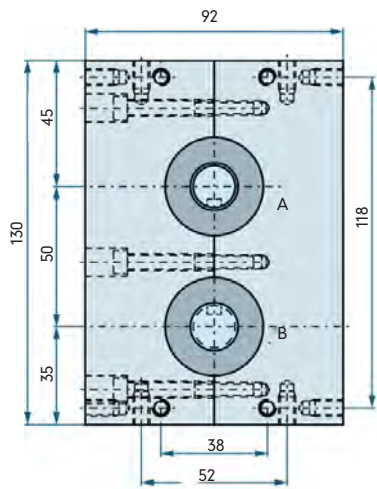

## XP050 Dimensions

The measurements shown here illustrate the standard unit. We will gladly customize the housing and or shaft(s) to suit your needs. The drive shaft as well as the output shaft are available as double sided shafts with and without keyways. If you would like to add additional holes into the housing yourself, please contact us for possible drilling depths.

A = Drive Shaft

B = Output Shaft



The dimensions for the gearmotor may change based on the gearmotor size and options required for the application.

# XP050 Load Table

Angle on Output Shaft [°]	Number of Stops n	Index Angle [°]	Acceleration Form MS	Indexer Torque $M_{AB}$ [Nm]			Moment of Inertia $J$ [kgm <sup>2</sup> ]			Mechanical Index Time $t_s$ [S]		
				n=50	n=100	n=200	n=50	n=100	n=200	n=50	n=100	n=200
360°	1	330	MS30	41	34	29	0.79	0.16	0.03	1.1	0.55	0.28
		300	MS50	41	34	29	0.81	0.17	0.04	1	0.5	0.25
180°	2	270	MS0	51	43	37	1.64	0.35	0.07	0.9	0.45	0.23
		210	MS30	49	42	36	1.11	0.24	0.05	0.7	0.35	0.18
		150	MS50	42	37	34	0.33	0.07	0.02	0.5	0.25	0.13
120°	3	270	MS0	54	49	43	3.02	0.69	0.15	0.9	0.45	0.23
		210	MS30	52	47	42	1.52	0.34	0.08	0.7	0.35	0.18
		150	MS30	45	40	33	0.67	0.15	0.03	0.5	0.25	0.13
		120	MS30	43	37	31	0.41	0.09	0.02	0.4	0.2	0.1
90°	4	270	MS0	47	43	38	3.51	0.8	0.18	0.9	0.45	0.23
		210	MS0	45	41	35	2.54	0.58	0.12	0.7	0.35	0.18
		150	MS30	41	37	31	1.02	0.23	0.05	0.5	0.25	0.13
		90	MS30	37	31	26	0.26	0.06	0.01	0.3	0.15	0.08
72°	5	270	MS0	47	43	38	4.38	1	0.22	0.9	0.45	0.23
		210	MS0	45	41	35	2.54	0.58	0.12	0.7	0.35	0.18
		150	MS30	41	37	31	1.02	0.23	0.05	0.5	0.25	0.13
		90	MS30	37	31	26	0.33	0.07	0.01	0.3	0.15	0.08
60°	6 <sup>1</sup>	270	MS0	59	57	53	6.61	1.6	0.37	0.9	0.45	0.23
		240	MS0	58	54	50	5.13	1.19	0.28	0.8	0.4	0.2
		180	MS30	50	46	41	2.15	0.49	0.11	0.6	0.3	0.15
		120	MS30	47	41	38	0.9	0.2	0.05	0.4	0.2	0.1
45°	8 <sup>1</sup>	270	MS0	59	57	53	8.81	2.13	0.49	0.9	0.45	0.23
		240	MS0	58	54	50	6.84	1.59	0.37	0.8	0.4	0.2
		180	MS30	50	46	41	2.86	0.66	0.15	0.6	0.3	0.15
		120	MS30	47	41	38	1.2	0.26	0.06	0.4	0.2	0.1
36°	10 <sup>1</sup>	270	MS0	59	57	53	11.01	2.66	0.62	0.9	0.45	0.23
		240	MS0	58	54	50	8.55	1.99	0.46	0.8	0.4	0.2
		180	MS30	50	46	41	3.58	0.82	0.18	0.6	0.3	0.15
		120	MS30	47	41	38	1.49	0.33	0.08	0.4	0.2	0.1
30°	12 <sup>2</sup>	240	MS0	41	38	31	7.25	1.68	0.34	0.8	0.4	0.2

<sup>1</sup>) Parallel drives with stop numbers 6, 8 and 10 are designed as a double index, i.e. with each full rotation of the drive shaft, two indexes occur in the output.

<sup>2</sup>) Parallel drives with 12 stops are designed as a four step index, i.e. with each full rotation of the drive shaft, four indexes occur in the output.

<sup>3</sup>) The additional load occurring with chains and belts due to friction is not taken into consideration here and must be calculated separately.

## Main Dimensions

Shaft distance [mm] 50  
 Weight without drive [kg] 2.5  
 Index angle [°] see Load Table  
 (other index angles upon request)  
 Number of stops 1,2,3,4,5,6,8,10,12  
 (other numbers of stops upon request)  
 Rotating direction right, left, oscillating  
 Mounting position ANY

## Capacities

Max. Output torque See Load Table  
 Input Shaft  
 Load rating dynamic [kN] 6.37  
 Load rating static [kN] 3.25  
 Output Shaft  
 Load rating dynamic [kN] 6.37  
 Load rating static [kN] 3.25



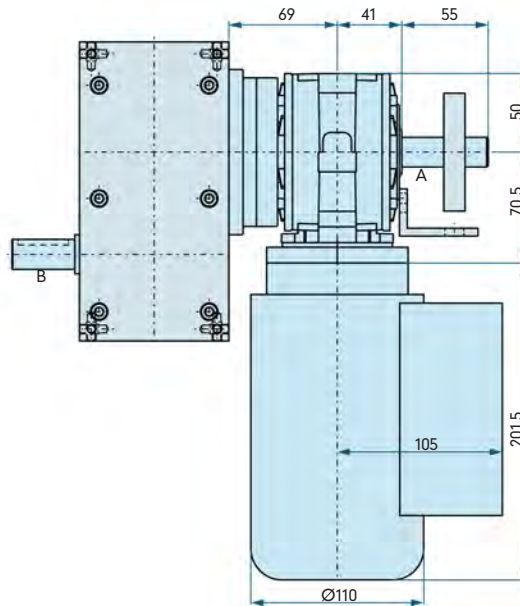
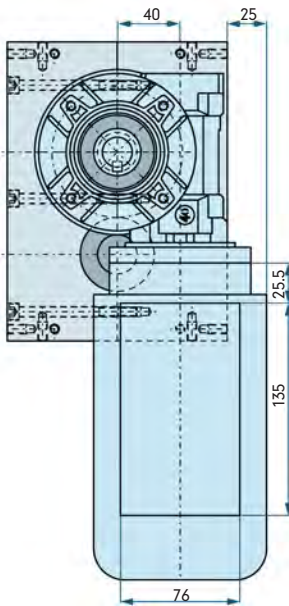
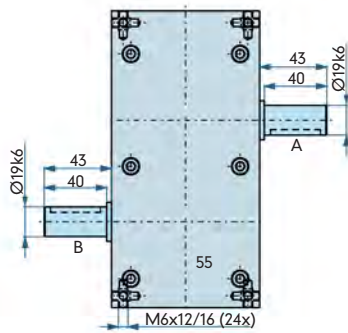
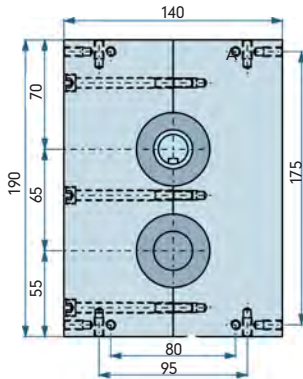

## XP065 Dimensions

The measurements shown here illustrate the standard unit. We will gladly customize the housing and or shaft(s) to suit your needs. The drive shaft as well as the output shaft are available as double sided shafts with and without keyways. If you would like to add additional holes into the housing yourself, please contact us for possible drilling depths.

A = Drive Shaft

B = Output Shaft



The dimensions for the gearmotor may change based on the gearmotor size and options required for the application.

# XP065 Load Table

Angle on Output Shaft [°]	Number of Stops n	Index Angle [°]	Acceleration Form MS	Indexer Torque $M_{AB}$ [Nm]			Moment of Inertia $J$ [kgm <sup>2</sup> ]			Mechanical Index Time $t_s$ [S]		
				n=50	n=100	n=200	n=50	n=100	n=200	n=50	n=100	n=200
360°	1	330	MS30	52	43	36	1	0.2	0.04	1.1	0.55	0.28
		300	MS50	48	39	30	1	0.2	0.04	1	0.5	0.25
180°	2	270	MS0	58	51	43	1.9	0.4	0.09	0.9	0.45	0.23
		210	MS30	48	46	41	1.1	0.3	0.06	0.7	0.35	0.18
		150	MS50	42	40	39	0.3	0.1	0.02	0.5	0.25	0.13
120°	3	270	MS0	74	68	59	4.1	1	0.21	0.9	0.45	0.23
		210	MS30	73	67	57	2.1	0.5	0.1	0.7	0.35	0.18
		150	MS30	61	53	46	0.9	0.2	0.04	0.5	0.25	0.13
		120	MS30	60	52	43	0.6	0.1	0.03	0.4	0.2	0.1
90°	4	270	MS0	68	61	53	5.1	1.1	0.25	0.9	0.45	0.23
		210	MS0	66	59	51	3	0.7	0.14	0.7	0.35	0.18
		150	MS30	64	57	49	1.3	0.3	0.06	0.5	0.25	0.13
		90	MS30	64	57	49	0.5	0.1	0.02	0.3	0.15	0.08
72°	5	270	MS0	68	61	53	6.3	1.4	0.31	0.9	0.45	0.23
		210	MS0	66	59	51	3.7	0.8	0.18	0.7	0.35	0.18
		150	MS30	64	57	49	1.6	0.4	0.08	0.5	0.25	0.13
		90	MS30	64	57	49	0.6	0.1	0.03	0.3	0.15	0.08
60°	6 <sup>1</sup>	270	MS0	86	71	56	9.6	2	0.39	0.9	0.45	0.23
		240	MS0	83	69	54	7.3	1.5	0.3	0.8	0.4	0.2
		180	MS30	79	65	51	3.4	0.7	0.14	0.6	0.3	0.15
		120	MS30	75	61	46	1.4	0.3	0.05	0.4	0.2	0.1
45°	8 <sup>1</sup>	270	MS0	86	71	56	12.8	2.6	0.52	0.9	0.45	0.23
		240	MS0	83	69	54	9.8	2	0.4	0.8	0.4	0.2
		180	MS30	79	65	51	4.5	0.9	0.18	0.6	0.3	0.15
		120	MS30	75	61	46	1.9	0.4	0.07	0.4	0.2	0.1
36°	10 <sup>1</sup>	270	MS0	86	71	56	16	3.3	0.65	0.9	0.45	0.23
		240	MS0	83	69	54	12.2	2.5	0.5	0.8	0.4	0.2
		180	MS30	79	65	51	5.7	1.2	0.23	0.6	0.3	0.15
		120	MS30	75	61	46	2.4	0.5	0.09	0.4	0.2	0.1
30°	12 <sup>2</sup>	240	MS0	62	51	39	11	2.3	0.43	0.8	0.4	0.2

<sup>1</sup>) Parallel drives with stop numbers 6, 8 and 10 are designed as a double index, i.e. with each full rotation of the drive shaft, two indexes occur in the output.

<sup>2</sup>) Parallel drives with 12 stops are designed as a four step index, i.e. with each full rotation of the drive shaft, four indexes occur in the output.

<sup>3</sup>) The additional load occurring with chains and belts due to friction is not taken into consideration here and must be calculated separately.

## Main Dimensions

Shaft distance [mm] 63  
 Weight without drive [kg] 8  
 Index angle [°] see Load Table  
 (other index angles upon request)  
 Number of stops 1,2,3,4,5,6,8,10,12  
 (other numbers of stops upon request)  
 Rotating Direction right, left, oscillating  
 Mounting position ANY

## Capacities

Max. Output torque See Load Table  
 Input Shaft  
 Load rating dynamic [kN] 11.9  
 Load rating static [kN] 6.55  
 Output Shaft  
 Load rating dynamic [kN] 8.06  
 Load rating static [kN] 4.75

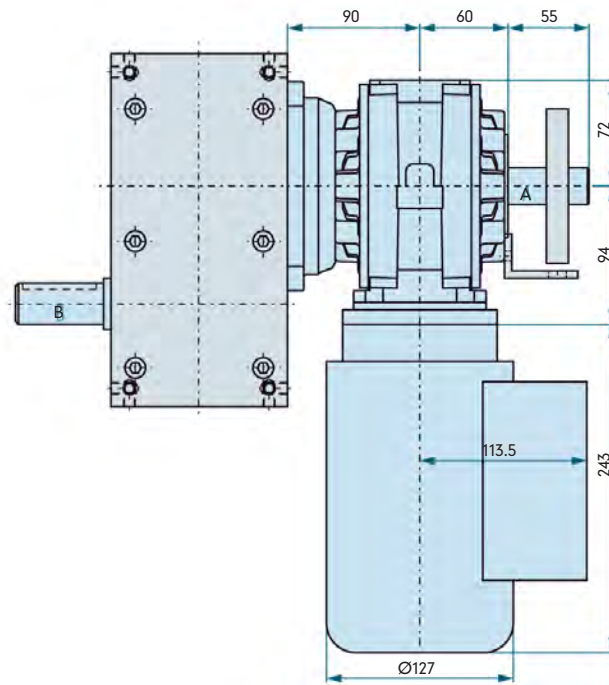
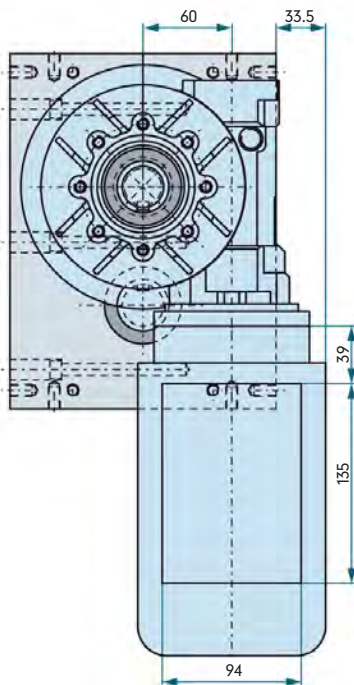
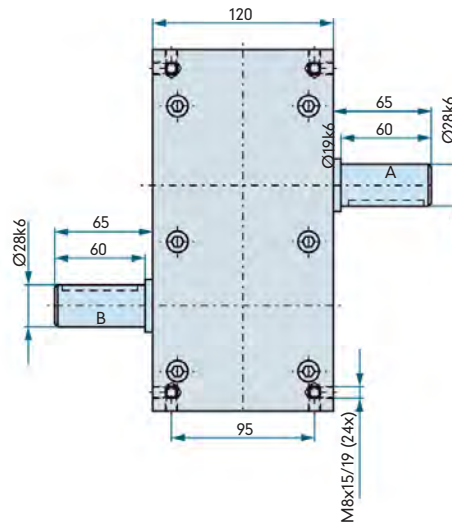
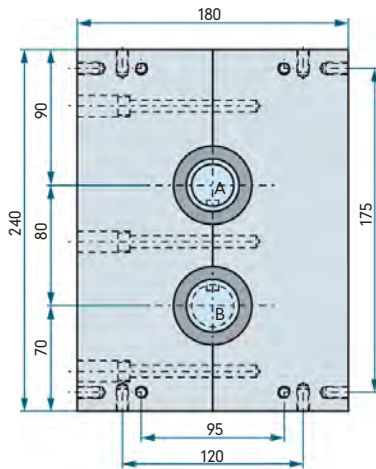

## XP080 Dimensions

The measurements shown here illustrate the standard unit. We will gladly customize the housing and or shaft(s) to suit your needs. The drive shaft as well as the output shaft are available as double sided shafts with and without keyways. If you would like to add additional holes into the housing yourself, please contact us for possible drilling depths.

A = Drive Shaft

B = Output Shaft



The dimensions for the gearmotor may change based on the gearmotor size and options required for the application.

# XP080 Load Table

Angle on Output Shaft [°]	Number of Stops n	Index Angle [°]	Acceleration Form MS	Indexer Torque $M_{AB}$ [Nm]			Moment of Inertia $J$ [kgm <sup>2</sup> ]			Mechanical Index Time $t_s$ [S]		
				n=50	n=100	n=200	n=50	n=100	n=200	n=50	n=100	n=200
360°	1	330	MS30	124	102	81	2.4	0.5	0.1	1.1	0.55	0.28
		300	MS50	123	101	79	2.4	0.5	0.1	1	0.5	0.25
180°	2	270	MS0	132	107	93	4.2	0.9	0.19	0.9	0.45	0.23
		210	MS30	131	107	93	3	0.6	0.13	0.7	0.35	0.18
		150	MS50	103	96	89	0.8	0.2	0.04	0.5	0.25	0.13
120°	3	270	MS0	159	137	112	8.9	1.9	0.39	0.9	0.45	0.23
		210	MS30	152	129	101	4.4	0.9	0.18	0.7	0.35	0.18
		150	MS30	127	103	83	1.9	0.4	0.08	0.5	0.25	0.13
		120	MS30	119	97	78	1.1	0.2	0.05	0.4	0.2	0.1
90°	4	270	MS0	157	132	109	11.7	2.5	0.51	0.9	0.45	0.23
		210	MS0	151	126	96	6.8	1.4	0.27	0.7	0.35	0.18
		150	MS30	138	112	88	2.7	0.6	0.11	0.5	0.25	0.13
		90	MS30	118	92	76	0.8	0.2	0.03	0.3	0.15	0.08
72°	5	270	MS0	157	132	109	14.6	3.1	0.64	0.9	0.45	0.23
		210	MS0	151	126	96	8.5	1.8	0.34	0.7	0.35	0.18
		150	MS30	138	112	88	3.4	0.7	0.14	0.5	0.25	0.13
		90	MS30	118	92	76	1.1	0.2	0.04	0.3	0.15	0.08
60°	6 <sup>1</sup>	270	MS0	186	149	124	20.8	4.2	0.87	0.9	0.45	0.23
		240	MS0	174	146	120	15.4	3.2	0.66	0.8	0.4	0.2
		180	MS30	160	122	96	6.9	1.3	0.26	0.6	0.3	0.15
		120	MS30	132	105	81	2.5	0.5	0.1	0.4	0.2	0.1
45°	8 <sup>1</sup>	270	MS0	186	149	124	27.8	5.6	1.16	0.9	0.45	0.23
		240	MS0	174	146	120	20.5	4.3	0.88	0.8	0.4	0.2
		180	MS30	160	122	96	9.2	1.7	0.34	0.6	0.3	0.15
		120	MS30	132	105	81	3.4	0.7	0.13	0.4	0.2	0.1
36°	10 <sup>1</sup>	270	MS0	186	149	124	34.7	7	1.45	0.9	0.45	0.23
		240	MS0	174	146	120	25.7	5.4	1.11	0.8	0.4	0.2
		180	MS30	160	122	96	11.4	2.2	0.43	0.6	0.3	0.15
		120	MS30	132	105	81	4.2	0.8	0.16	0.4	0.2	0.1
30°	12 <sup>2</sup>	240	MS0	110	95	76	19.5	4.2	0.84	0.8	0.4	0.2

<sup>1</sup>) Parallel drives with stop numbers 6, 8 and 10 are designed as a double index, i.e. with each full rotation of the drive shaft, two indexes occur in the output.

<sup>2</sup>) Parallel drives with 12 stops are designed as a four step index, i.e. with each full rotation of the drive shaft, four indexes occur in the output.

<sup>3</sup>) The additional load occurring with chains and belts due to friction is not taken into consideration here and must be calculated separately.

## Main Dimensions

Shaft distance [mm]	80
Weight without drive [kg]	12
Switching angle [°]	see Load Table
(other switching angles upon request)	
Number of stops	1,2,3,4,5,6,8,10,12
(other numbers of stops upon request)	
Rotating direction	right, left, oscillating
Mounting position	ANY

## Capacities

Max. Output torque	See Load Table
Input Shaft	
Load rating dynamic [kN]	13.8
Load rating static [kN]	8.3
Output Shaft	
Load rating dynamic [kN]	13.8
Load rating static [kN]	8.3

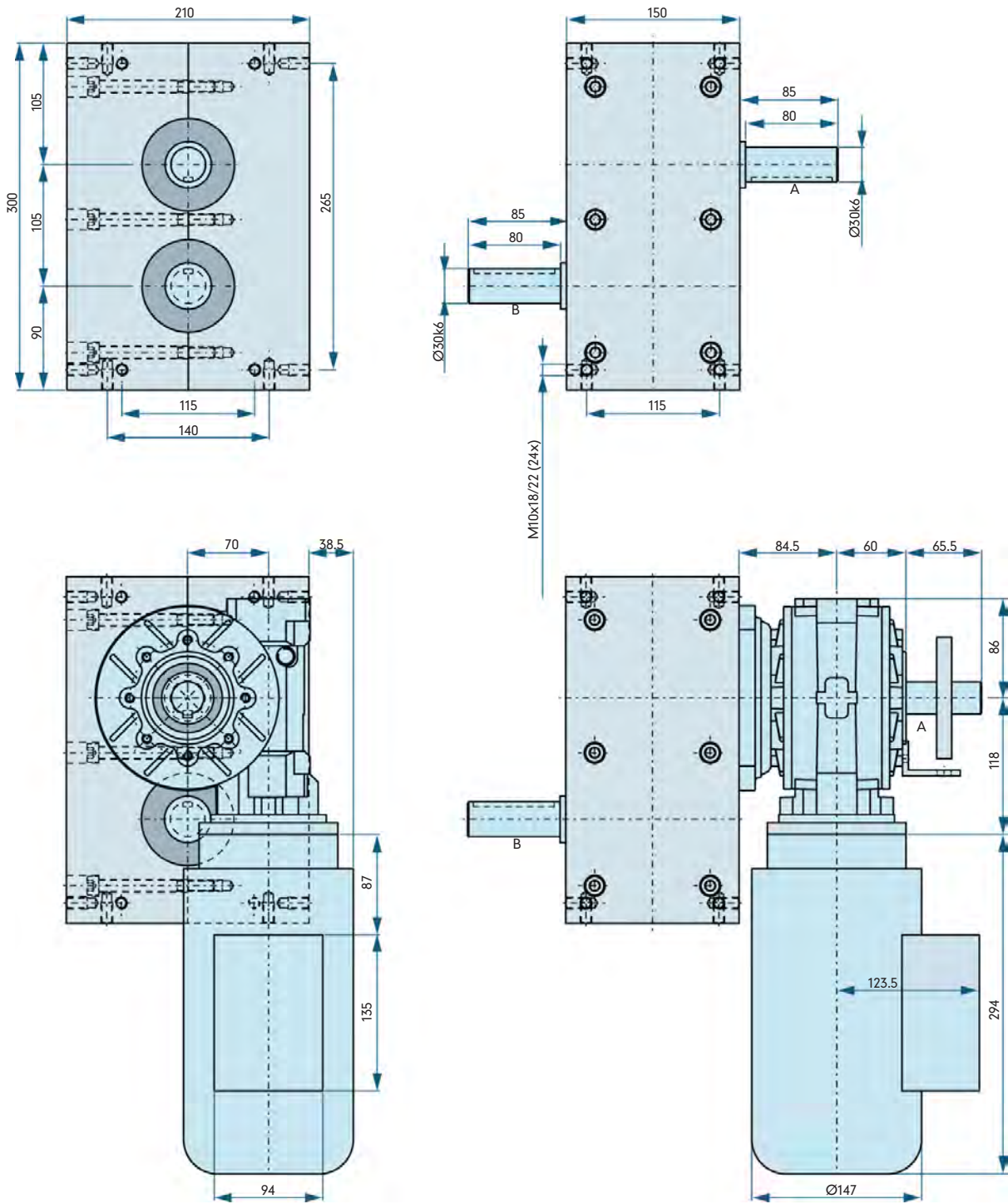

## XP105 Dimensions

The measurements shown here illustrate the standard unit. We will gladly customize the housing and or shaft(s) to suit your needs. The drive shaft as well as the output shaft are available as double sided shafts with and without keyways. If you would like to add additional holes into the housing yourself, please contact us for possible drilling depths.

A = Drive Shaft

B = Output Shaft



The dimensions for the gearmotor may change based on the gearmotor size and options required for the application.

# XP105 Load Table

Angle on Output Shaft [°]	Number of Stops n	Index Angle [°]	Acceleration Form MS	Indexer Torque $M_{AB}$ [Nm]			Moment of Inertia $J$ [kgm <sup>2</sup> ]			Mechanical Index Time $t_s$ [S]		
				n=50	n=100	n=200	n=50	n=100	n=200	n=50	n=100	n=200
360°	1	330	MS30	216	175	138	4.2	0.8	0.2	1.1	0.55	0.28
		300	MS50	208	171	132	4.1	0.8	0.2	1	0.5	0.25
180°	2	270	MS0	297	265	230	9.6	2.1	0.5	0.9	0.45	0.23
		210	MS30	285	251	221	6.4	1.4	0.3	0.7	0.35	0.18
		150	MS50	254	204	155	2	0.4	0.1	0.5	0.25	0.13
120°	3	270	MS0	361	319	278	20.2	4.5	1	0.9	0.45	0.23
		210	MS30	350	312	270	10.2	2.3	0.5	0.7	0.35	0.18
		150	MS30	344	306	261	5.1	1.1	0.2	0.5	0.25	0.13
		120	MS30	340	301	256	3.2	0.7	0.2	0.4	0.2	0.1
90°	4	270	MS0	341	298	245	25.5	5.6	1.1	0.9	0.45	0.23
		210	MS0	330	291	238	14.9	3.3	0.7	0.7	0.35	0.18
		150	MS30	318	279	226	6.3	1.4	0.3	0.5	0.25	0.13
		90	MS30	292	269	221	2.1	0.5	0.1	0.3	0.15	0.08
72°	5	270	MS0	341	298	245	31.8	7	1.4	0.9	0.45	0.23
		210	MS0	330	291	238	18.6	4.1	0.8	0.7	0.35	0.18
		150	MS30	318	279	226	7.9	1.7	0.4	0.5	0.25	0.13
		90	MS30	292	269	221	2.6	0.6	0.1	0.3	0.15	0.08
60°	6 <sup>1</sup>	270	MS0	391	351	298	43.8	9.8	2.1	0.9	0.45	0.23
		240	MS0	377	339	286	33.3	7.5	1.6	0.8	0.4	0.2
		180	MS30	305	260	202	13.1	2.8	0.5	0.6	0.3	0.15
		120	MS30	281	239	180	5.4	1.1	0.2	0.4	0.2	0.1
45°	8 <sup>1</sup>	270	MS0	391	351	298	58.4	13.1	2.8	0.9	0.45	0.23
		240	MS0	377	339	286	44.5	1	2.1	0.8	0.4	0.2
		180	MS30	305	260	202	17.5	3.7	0.7	0.6	0.3	0.15
		120	MS30	281	239	180	7.1	1.5	0.3	0.4	0.2	0.1
36°	10 <sup>1</sup>	270	MS0	391	351	298	73	16.4	3.5	0.9	0.45	0.23
		240	MS0	377	339	286	55.6	12.5	2.6	0.8	0.4	0.2
		180	MS30	305	260	202	21.8	4.7	0.9	0.6	0.3	0.15
		120	MS30	281	239	180	8.9	1.9	0.4	0.4	0.2	0.1
30°	12 <sup>2</sup>	240	MS0	270	220	170	47.8	9.7	1.9	0.8	0.4	0.2

<sup>1</sup>) Parallel drives with stop numbers 6, 8 and 10 are designed as a double index, i.e. with each full rotation of the drive shaft, two indexes occur in the output.

<sup>2</sup>) Parallel drives with 12 stops are designed as a four step index, i.e. with each full rotation of the drive shaft, four indexes occur in the output.

<sup>3</sup>) The additional load occurring with chains and belts due to friction is not taken into consideration here and must be calculated separately.

## Main Dimensions

Shaft distance [mm] 105  
 Weight without drive [kg] 32  
 Switching angle [°] see Load Table  
 (other switching angles upon request)  
 Number of stops 1,2,3,4,5,6,8,10,12  
 (other numbers of stops upon request)  
 Rotating direction right, left, oscillating  
 Mounting position

## Capacities

Max. Output torque See Load Table  
 Input Shaft  
 Load rating dynamic [kN] 30.7  
 Load rating static [kN] 19  
 Output Shaft  
 Load rating dynamic [kN] 30.7  
 Load rating static [kN] 19

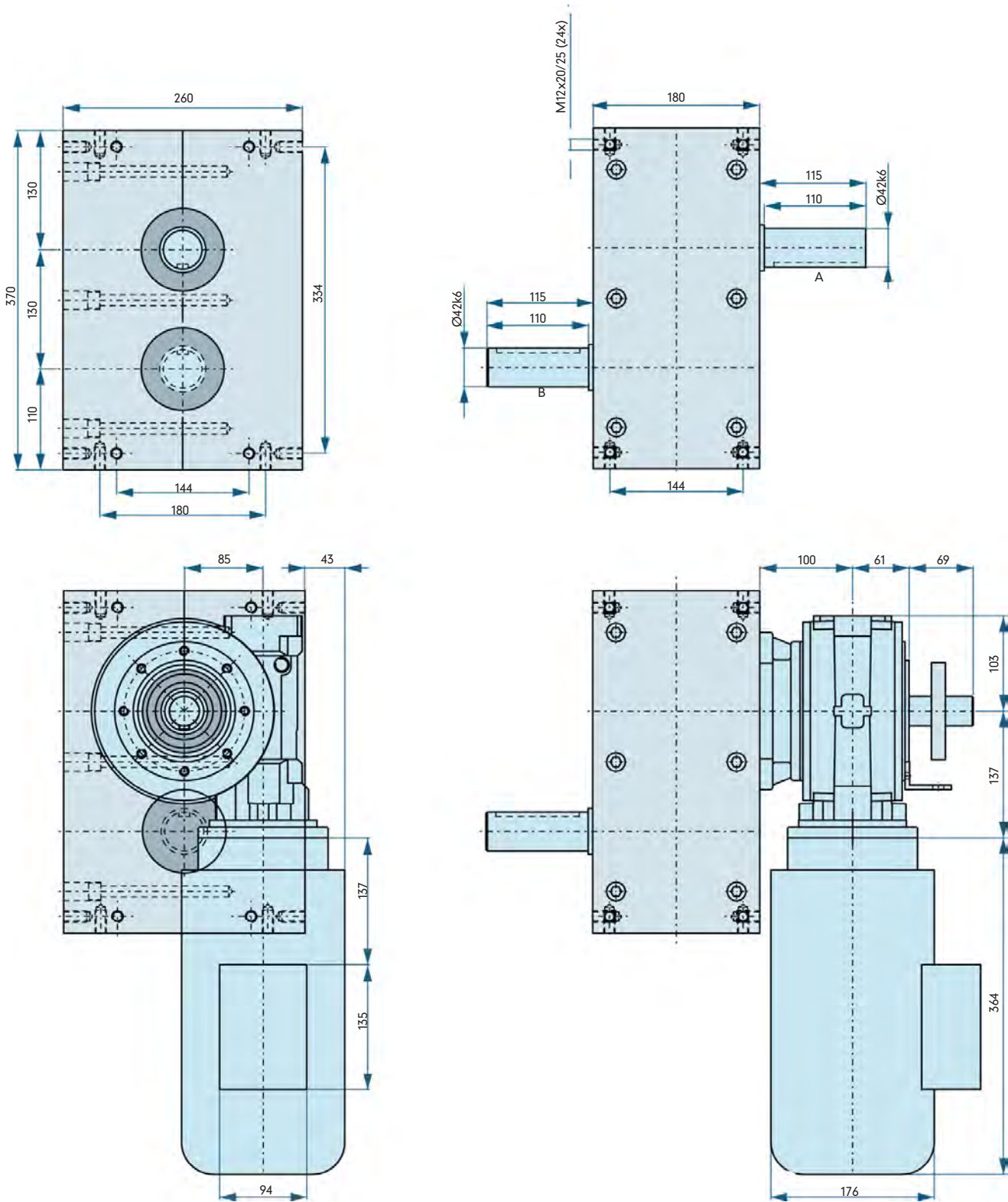

## XP130 Dimensions

The measurements shown here illustrate the standard unit. We will gladly customize the housing and or shaft(s) to suit your needs. The drive shaft as well as the output shaft are available as double sided shafts with and without keyways. If you would like to add additional holes into the housing yourself, please contact us for possible drilling depths.

A = Drive Shaft

B = Output Shaft



The dimensions for the gearmotor may change based on the gearmotor size and options required for the application.

# XP130 Load Table

Angle on Output Shaft [°]	Number of Stops n	Index Angle [°]	Acceleration Form MS	Indexer Torque $M_{AB}$ [Nm]			Moment of Inertia $J$ [kgm <sup>2</sup> ]			Mechanical Index Time $t_s$ [S]		
				n=50	n=100	n=200	n=50	n=100	n=200	n=50	n=100	n=200
360°	1	330	MS30	359	290	227	6.9	1.4	0.3	1.1	0.55	0.28
		300	MS50	350	278	210	7	1.4	0.3	1	0.5	0.25
180°	2	270	MS0	449	370	302	14.5	3	0.6	0.9	0.45	0.23
		210	MS30	372	283	213	8.4	1.6	0.3	0.7	0.35	0.18
		150	MS50	310	228	165	2.5	0.5	0.1	0.5	0.25	0.13
120°	3	270	MS0	554	460	375	31	6.4	1.3	0.9	0.45	0.23
		210	MS30	520	436	360	15.2	3.2	0.7	0.7	0.35	0.18
		150	MS30	415	330	240	6.2	1.2	0.2	0.5	0.25	0.13
		120	MS30	390	285	210	3.7	0.7	0.1	0.4	0.2	0.1
90°	4	270	MS0	540	455	360	40.3	8.5	1.7	0.9	0.45	0.23
		210	MS0	501	413	325	22.6	4.7	0.9	0.7	0.35	0.18
		150	MS30	480	390	294	9.5	1.9	0.4	0.5	0.25	0.13
		90	MS30	440	346	263	3.1	0.6	0.1	0.3	0.15	0.08
72°	5	270	MS0	540	455	360	50.4	10.6	2.1	0.9	0.45	0.23
		210	MS0	501	413	325	28.3	5.8	1.1	0.7	0.35	0.18
		150	MS30	480	390	294	11.9	2.4	0.5	0.5	0.25	0.13
		90	MS30	440	346	263	3.9	0.8	0.1	0.3	0.15	0.08
60°	6 <sup>1</sup>	270	MS0	615	537	442	68.9	15	3.1	0.9	0.45	0.23
		240	MS0	576	483	390	51	10.7	2.2	0.8	0.4	0.2
		180	MS30	445	368	280	19.1	3.9	0.8	0.6	0.3	0.15
		120	MS30	395	320	239	7.5	1.5	0.3	0.4	0.2	0.1
45°	8 <sup>1</sup>	270	MS0	615	537	442	91.8	20	4.1	0.9	0.45	0.23
		240	MS0	576	483	390	67.9	14.2	2.9	0.8	0.4	0.2
		180	MS30	445	368	280	25.5	5.3	1	0.6	0.3	0.15
		120	MS30	395	320	239	10	2	0.4	0.4	0.2	0.1
36°	10 <sup>1</sup>	270	MS0	615	537	442	114.8	25	5.2	0.9	0.45	0.23
		240	MS0	576	483	390	84.9	17.8	3.6	0.8	0.4	0.2
		180	MS30	445	368	280	31.8	6.6	1.3	0.6	0.3	0.15
		120	MS30	395	320	239	12.6	2.5	0.5	0.4	0.2	0.1
30°	12 <sup>2</sup>	240	MS0	360	290	230	63.7	12.8	2.5	0.8	0.4	0.2

<sup>1</sup>) Parallel drives with stop numbers 6, 8 and 10 are designed as a double index, i.e. with each full rotation of the drive shaft, two indexes occur in the output.

<sup>2</sup>) Parallel drives with 12 stops are designed as a four step index, i.e. with each full rotation of the drive shaft, four indexes occur in the output.

<sup>3</sup>) The additional load occurring with chains and belts due to friction is not taken into consideration here and must be calculated separately.

## Main Dimensions

Shaft distance [mm] 130  
 Weight without drive [kg] 45  
 Switching angle [°] see Load Table  
 (other switching angles upon request)  
 Number of stops 1,2,3,4,5,6,8,10,12  
 (other numbers of stops upon request)  
 Rotating direction right, left, oscillating  
 Mounting position ANY

## Capacities

Max. Output torque See Load Table  
 Input Shaft  
 Load rating dynamic [kN] 51  
 Load rating static [kN] 39  
 Output Shaft  
 Load rating dynamic [kN] 51  
 Load rating static [kN] 39



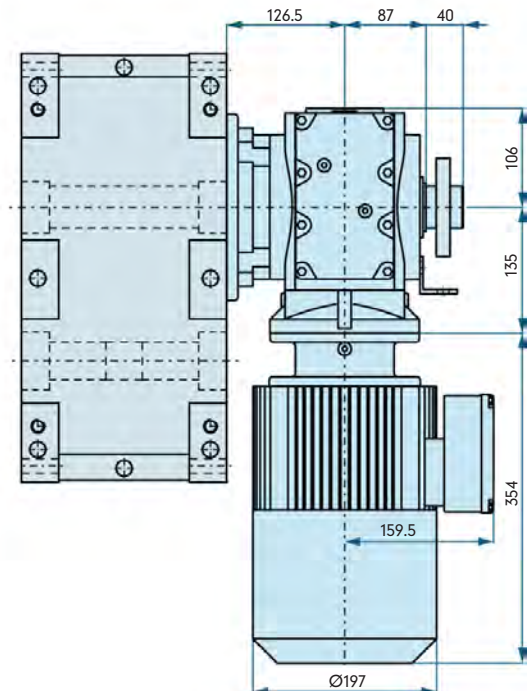
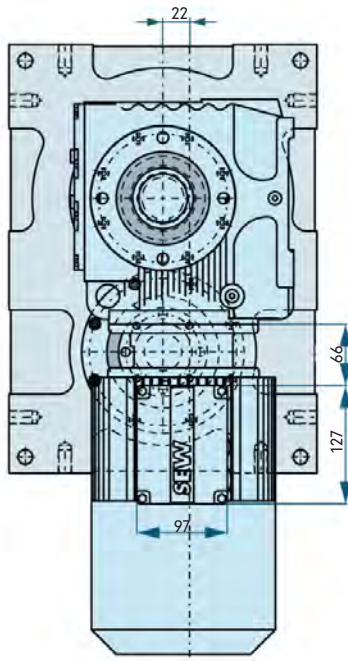
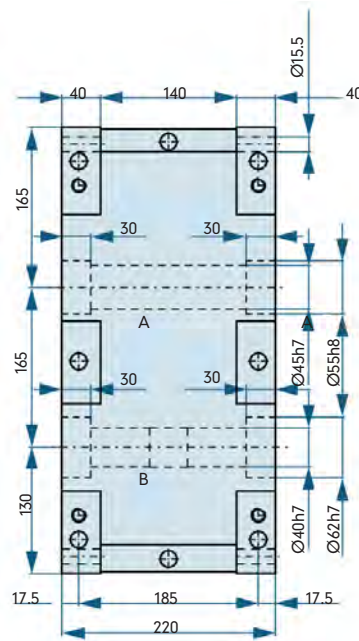
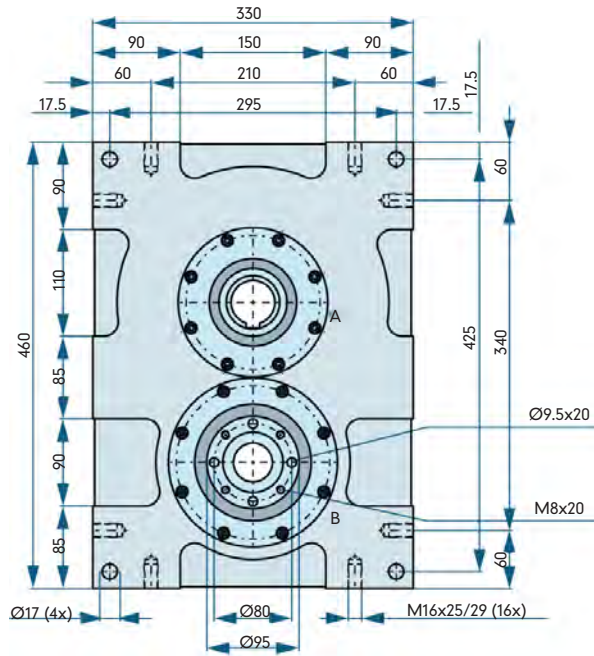

## XP165 Dimensions

The measurements shown here illustrate the standard unit. We will gladly customize the housing and or shaft(s) to suit your needs. The drive shaft as well as the output shaft are available as double sided shafts with and without keyways. If you would like to add additional holes into the housing yourself, please contact us for possible drilling depths.

A = Drive Shaft

B = Output Shaft



The dimensions for the gearmotor may change based on the gearmotor size and options required for the application.

# XP165 Load Table

Angle on Output Shaft [°]	Number of Stops n	Index Angle [°]	Acceleration Form MS	Indexer Torque $M_{AB}$ [Nm]			Moment of Inertia $J$ [kgm <sup>2</sup> ]			Mechanical Index Time $t_s$ [S]		
				n=50	n=100	n=200	n=50	n=100	n=200	n=50	n=100	n=200
360°	1	330	MS30	920	760	615	17.7	3.7	0.7	1.1	0.55	0.28
		300	MS50	890	735	580	17.7	3.7	0.7	1	0.5	0.25
180°	2	270	MS0	930	840	680	29.9	6.8	1.4	0.9	0.45	0.23
		210	MS30	805	780	630	18.2	4.4	0.9	0.7	0.35	0.18
		150	MS50	790	740	600	6.3	1.5	0.3	0.5	0.25	0.13
120°	3	270	MS0	950	920	680	53.2	12.9	2.4	0.9	0.45	0.23
		210	MS30	840	810	590	24.5	5.9	1.1	0.7	0.35	0.18
		150	MS30	820	790	570	12.2	2.9	0.5	0.5	0.25	0.13
		120	MS30	805	770	540	7.7	1.8	0.3	0.4	0.2	0.1
90°	4	270	MS0	950	920	680	70.9	17.2	3.2	0.9	0.45	0.23
		210	MS0	840	810	590	37.9	9.1	1.7	0.7	0.35	0.18
		150	MS30	820	790	570	16.3	3.9	0.7	0.5	0.25	0.13
		90	MS30	805	770	540	5.8	1.4	0.2	0.3	0.15	0.08
72°	5	270	MS0	950	920	680	88.6	21.5	4	0.9	0.45	0.23
		210	MS0	840	810	590	47.4	11.4	2.1	0.7	0.35	0.18
		150	MS30	820	790	570	20.4	4.9	0.9	0.5	0.25	0.13
		90	MS30	805	770	540	7.2	1.7	0.3	0.3	0.15	0.08
60°	6 <sup>1</sup>	270	MS0	930	920	890	104.1	25.7	6.2	0.9	0.45	0.23
		240	MS0	910	900	870	80.5	19.9	4.8	0.8	0.4	0.2
		180	MS30	890	880	850	38.2	9.4	2.3	0.6	0.3	0.15
		120	MS30	860	840	820	16.4	4	1	0.4	0.2	0.1
45°	8 <sup>1</sup>	270	MS0	790	770	750	117.9	28.7	7	0.9	0.45	0.23
		240	MS0	770	750	730	90.8	22.1	5.4	0.8	0.4	0.2
		180	MS30	760	740	710	43.5	10.6	1.1	0.6	0.3	0.15
		120	MS30	750	730	720	19.1	4.6	1.1	0.4	0.2	0.1
36°	10 <sup>1</sup>	270	MS0	790	770	750	147.4	35.9	8.7	0.9	0.45	0.23
		240	MS0	770	750	730	113.5	27.6	6.7	0.8	0.4	0.2
		180	MS30	760	750	730	113.5	27.6	6.7	0.6	0.3	0.15
		120	MS30	750	730	720	23.8	5.8	1.4	0.4	0.2	0.1
30°	12 <sup>2</sup>	240	MS0	730	720	700	129.1	31.8	7.7	0.8	0.4	0.2

<sup>1</sup>) Parallel drives with stop numbers 6, 8 and 10 are designed as a double index, i.e. with each full rotation of the drive shaft, two indexes occur in the output.

<sup>2</sup>) Parallel drives with 12 stops are designed as a four step index, i.e. with each full rotation of the drive shaft, four indexes occur in the output.

<sup>3</sup>) The additional load occurring with chains and belts due to friction is not taken into consideration here and must be calculated separately.

## Main Dimensions

Shaft distance [mm]	165
Weight without drive [kg]	120
Switching angle [°]	see Load Table
(other switching angles upon request)	
Number of stops	1,2,3,4,5,6,8,10,12
(other numbers of stops upon request)	
Rotating direction	right, left, oscillating
Mounting position	ANY

## Capacities

Max. Output torque	See Load Table
Input Shaft	
Load rating dynamic [kN]	116
Load rating static [kN]	153
Output Shaft	
Load rating dynamic [kN]	168
Load rating static [kN]	270

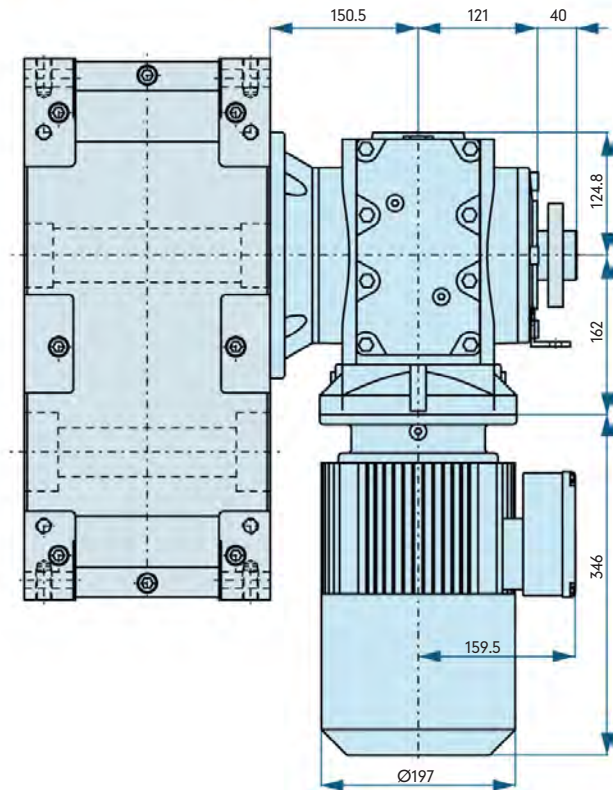
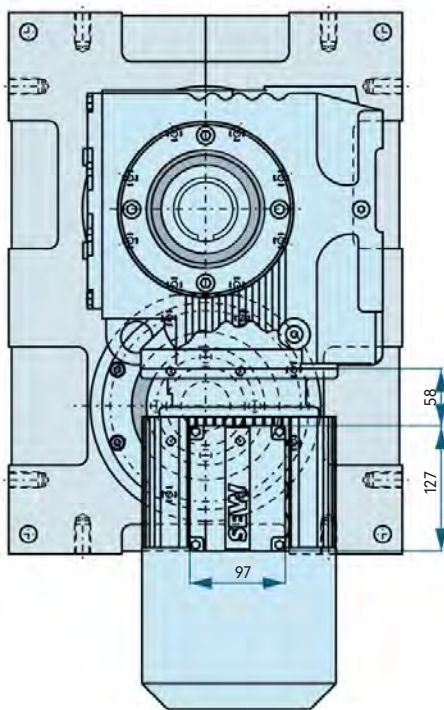
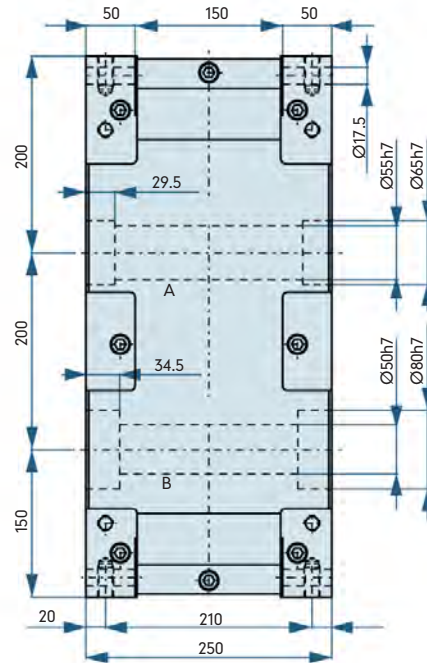
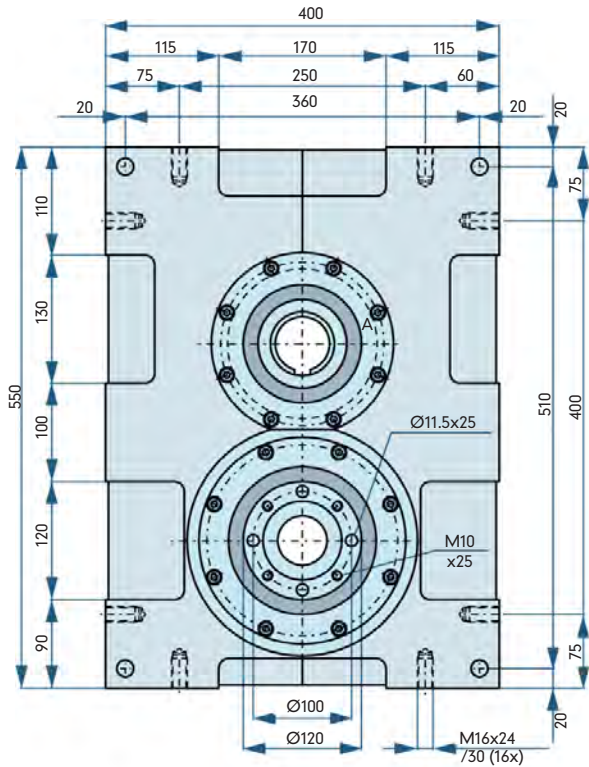

## XP200 Dimensions

The measurements shown here illustrate the standard unit. We will gladly customize the housing and or shaft(s) to suit your needs. The drive shaft as well as the output shaft are available as double sided shafts with and without keyways. If you would like to add additional holes into the housing yourself, please contact us for possible drilling depths.

A = Drive Shaft

B = Output Shaft



The dimensions for the gearmotor may change based on the gearmotor size and options required for the application.

# XP200 Load Table

Angle on Output Shaft [°]	Number of Stops n	Index Angle [°]	Acceleration Form MS	Indexer Torque $M_{AB}$ [Nm]			Moment of Inertia $J$ [kgm <sup>2</sup> ]			Mechanical Index Time $t_s$ [S]		
				n=50	n=100	n=200	n=50	n=100	n=200	n=50	n=100	n=200
360°	1	330	MS30	1530	1255	1004	29	6	1.2	1.1	0.55	0.28
		300	MS50	1450	1190	950	29	5.9	1.2	1	0.5	0.25
180°	2	270	MS0	1590	1305	1040	51	10.5	2.1	0.9	0.45	0.23
		210	MS30	1460	1200	960	33	6.8	1.4	0.7	0.35	0.18
		150	MS50	1390	1140	910	11	2.3	0.5	0.5	0.25	0.13
120°	3	270	MS0	1680	1380	1100	94	19.3	3.8	0.9	0.45	0.23
		210	MS30	1590	1305	1045	46	9.5	1.9	0.7	0.35	0.18
		150	MS30	1490	1220	980	22	4.5	0.9	0.5	0.25	0.13
		120	MS30	1480	1215	970	14	2.9	0.6	0.4	0.2	0.1
90°	4	270	MS0	1470	1205	965	110	22.5	4.5	0.9	0.45	0.23
		210	MS0	1440	1181	945	65	13.3	2.7	0.7	0.35	0.18
		150	MS30	1390	1140	910	28	5.7	1.1	0.5	0.25	0.13
		90	MS30	1370	1120	900	10	2	0.4	0.3	0.15	0.08
72°	5	270	MS0	1470	1205	965	137	28.1	5.6	0.9	0.45	0.23
		210	MS0	1440	1180	945	81	16.8	3.3	0.7	0.35	0.18
		150	MS30	1390	1140	910	35	7.1	1.34	0.5	0.25	0.13
		90	MS30	1370	1125	900	12	2.5	0.5	0.3	0.15	0.08
60°	6 <sup>1</sup>	270	MS0	1520	1430	1340	170	40	9.4	0.9	0.45	0.23
		240	MS0	1490	1220	980	132	27	5.4	0.8	0.4	0.2
		180	MS30	1460	1370	1270	63	14.7	3.4	0.6	0.3	0.15
		120	MS30	1420	1335	1240	27	6.4	1.5	0.4	0.2	0.1
45°	8 <sup>1</sup>	270	MS0	1290	1210	1140	193	45.2	10.6	0.9	0.45	0.23
		240	MS0	1270	1195	1120	150	35.2	8.3	0.8	0.4	0.2
		180	MS30	1260	1180	1110	72	16.9	4	0.6	0.3	0.15
		120	MS30	1240	1166	1100	32	7.4	1.7	0.4	0.2	0.1
36°	10 <sup>1</sup>	270	MS0	1290	1210	1140	241	56.4	13.3	0.9	0.45	0.23
		240	MS0	1270	1195	1120	187	44	10.3	0.8	0.4	0.2
		180	MS30	1260	1180	1110	90	21.1	5	0.6	0.3	0.15
		120	MS30	1240	1166	1100	39	9.3	2.2	0.4	0.2	0.1
30°	12 <sup>2</sup>	240	MS0	1190	1140	1090	211	50.4	12.1	0.8	0.4	0.2

<sup>1</sup>) Parallel drives with stop numbers 6, 8 and 10 are designed as a double index, i.e. with each full rotation of the drive shaft, two indexes occur in the output.

<sup>2</sup>) Parallel drives with 12 stops are designed as a four step index, i.e. with each full rotation of the drive shaft, four indexes occur in the output.

<sup>3</sup>) The additional load occurring with chains and belts due to friction is not taken into consideration here and must be calculated separately.

## Main Dimensions

Shaft distance [mm]	200
Weight without drive [kg]	220
Switching angle [°]	see Load Table
(other switching angles upon request)	
Number of stops	1,2,3,4,5,6,8,10,12
(other numbers of stops upon request)	
Rotating direction	right, left, oscillating
Mounting position	

## Capacities

Max. Output torque	See Load Table
Input Shaft	
Load rating dynamic [kN]	168
Load rating static [kN]	270
Output Shaft	
Load rating dynamic [kN]	242
Load rating static [kN]	415



# XP250 Load Table

Angle on Output Shaft [°]	Number of Stops n	Index Angle [°]	Acceleration Form MS	Indexer Torque $M_{AB}$ [Nm]			Moment of Inertia $J$ [kgm <sup>2</sup> ]			Mechanical Index Time $t_s$ [S]		
				n=50	n=100	n=200	n=50	n=100	n=200	n=50	n=100	n=200
360°	1	330	MS30	2750	2255	1827	53	10.9	2.2	1.1	0.55	0.28
		300	MS50	2680	2020	1635	53	10	2	1	0.5	0.25
180°	2	270	MS0	2710	2300	1860	90	18.5	3.7	0.9	0.45	0.23
		210	MS30	2480	2035	1650	56	11.5	2.3	0.7	0.35	0.18
		150	MS50	2430	1990	1610	19	4	0.8	0.5	0.25	0.13
120°	3	270	MS0	2870	2350	1905	161	32.9	6.7	0.9	0.45	0.23
		210	MS30	2690	2200	1780	79	16.1	3.3	0.7	0.35	0.18
		150	MS30	2510	2060	1665	37	7.7	1.6	0.5	0.25	0.13
		120	MS30	2490	2040	1655	24	4.9	1	0.4	0.2	0.1
90°	4	270	MS0	2690	2205	1790	201	41.1	8.3	0.9	0.45	0.23
		210	MS0	2670	2189	1773	121	24.7	5	0.7	0.35	0.18
		150	MS30	2570	2110	1710	52	10.6	2.2	0.5	0.25	0.13
		90	MS30	2570	2110	1710	18	3.8	0.8	0.3	0.15	0.08
72°	5	270	MS0	2690	2205	1790	251	51.4	10.4	0.9	0.45	0.23
		210	MS0	2370	2189	1773	151	30.9	6.3	0.7	0.35	0.18
		150	MS30	2610	2140	1734	65	13.3	2.7	0.5	0.25	0.13
		90	MS30	2570	2110	1710	23	4.7	1	0.3	0.15	0.08
60°	6 <sup>1</sup>	270	MS0	2810	2700	2570	315	75.6	18	0.9	0.45	0.23
		240	MS0	2730	2630	2510	241	58.2	13.9	0.8	0.4	0.2
		180	MS30	2590	2490	2310	111	26.7	6.2	0.6	0.3	0.15
		120	MS30	2540	2410	2260	48	11.5	2.7	0.4	0.2	0.1
45°	8 <sup>1</sup>	270	MS0	2530	2400	2290	378	89.6	21.4	0.9	0.45	0.23
		240	MS0	2470	2370	2210	291	69.9	16.3	0.8	0.4	0.2
		180	MS30	2410	2300	2180	138	32.9	7.8	0.6	0.3	0.15
		120	MS30	2380	2270	2150	61	14.4	3.4	0.4	0.2	0.1
36°	10 <sup>1</sup>	270	MS0	2530	2400	2290	472	112	26.7	0.9	0.45	0.23
		240	MS0	2470	2370	2210	364	87.4	20.4	0.8	0.4	0.2
		180	MS30	2410	2300	2180	172	41.1	9.7	0.6	0.3	0.15
		120	MS30	2380	2270	2150	76	18	4.3	0.4	0.2	0.1
30°	12 <sup>2</sup>	240	MS0	2250	2120	1990	398	93.8	22	0.8	0.4	0.2

<sup>1</sup>) Parallel drives with stop numbers 6, 8 and 10 are designed as a double index, i.e. with each full rotation of the drive shaft, two indexes occur in the output.

<sup>2</sup>) Parallel drives with 12 stops are designed as a four step index, i.e. with each full rotation of the drive shaft, four indexes occur in the output.

<sup>3</sup>) The additional load occurring with chains and belts due to friction is not taken into consideration here and must be calculated separately.

## Main Dimensions

Shaft distance [mm]	250
Weight without drive [kg]	350
Switching angle [°]	see Load Table
(other switching angles upon request)	
Number of stops	1,2,3,4,5,6,8,10,12
(other numbers of stops upon request)	
Rotating direction	right, left, oscillating
Mounting position	ANY

## Capacities

Max. Output torque	See Load Table
Input Shaft	
Load rating dynamic [kN]	242
Load rating static [kN]	415
Output Shaft	
Load rating dynamic [kN]	365
Load rating static [kN]	655