



PSFN

The precision planetary gearbox for maximum loads with particularly quiet drive and flange output shaft

Thanks to its standardized flange interface, our **PSFN** can be installed easily and reliably. Our Neugart-designed helical teeth makes additional noise absorption measures absolute. Thanks to its high tilting moment, you may demand the utmost from this precision planetary gearbox.

Nominal output torque **28 - 950 Nm**

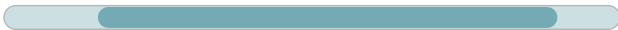

Radial force **2150 - 23000 N**

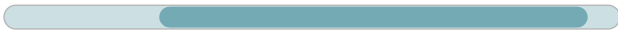

Axial force **4300 - 16000 N**



Torsional backlash **1 - 5 arcmin**



Protection class **IP65**



Frame sizes

- 64
- 90
- 110
- 140
- 200

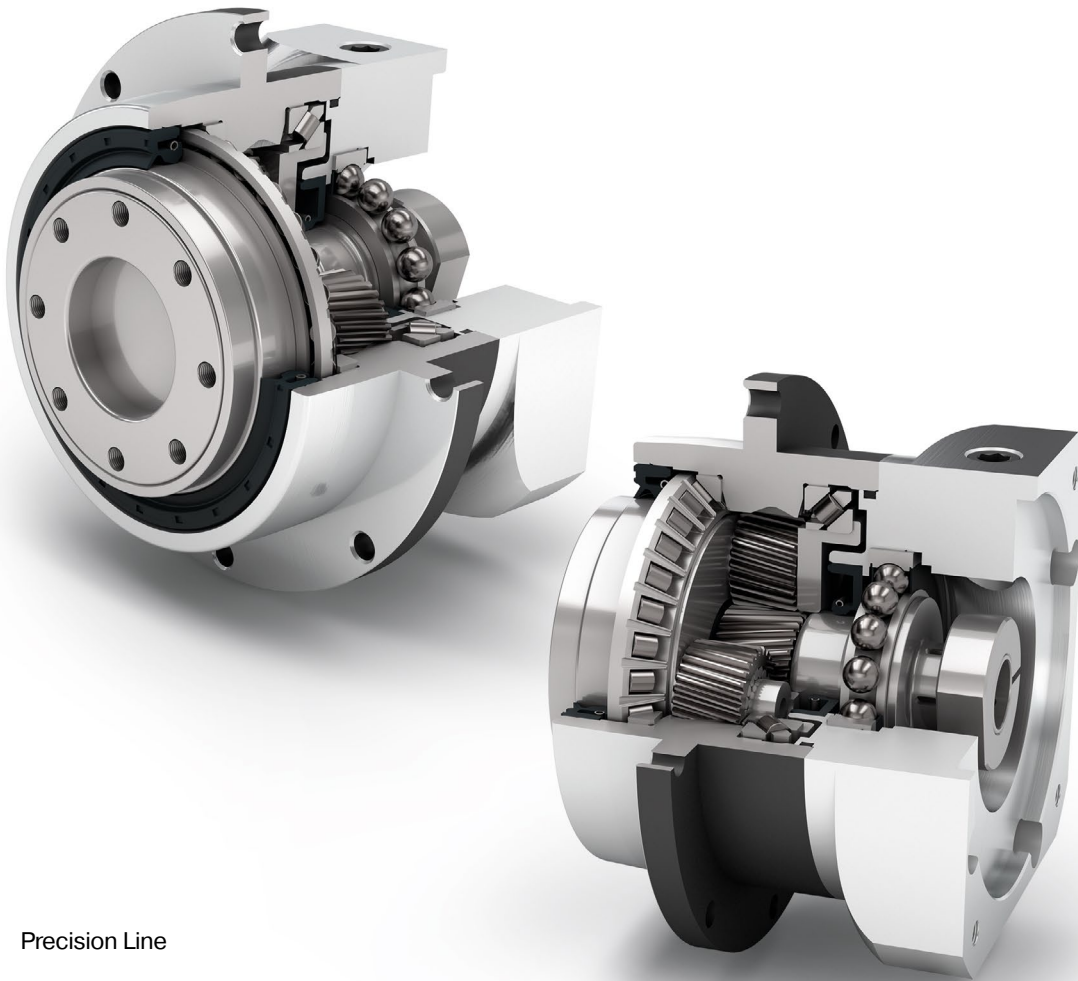

Precision Line

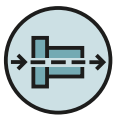

Coaxial gearbox



Helical gear



Preloaded angular contact roller bearings



Flange output shaft (ISO 9409)



Option: Reduced backlash



Equidirectional rotation

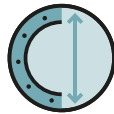

Extra large round type output flange



Rotary shaft seal



Planet carrier in cage design



Option: Planetary gearbox with mounted pinion on page 140

Detailed explanations of the technical features starting on page 169.

Code	Gearbox characteristics			PSFN064	PSFN090	PSFN110	PSFN140	PSFN200	p ⁽¹⁾
	Service life (L _{10h})	t _L	h	20.000					
	Service life at T _{2N} x 0.88			30.000					
	Efficiency at full load ⁽²⁾	η	%	97					1
				96					2
	Min. operating temperature	T _{min}	°C (°F)	-25 (-13)					
	Max. operating temperature	T _{max}		90 (194)					
	Protection class				IP65				
S	Standard lubrication				Oil (lifetime lubrication)				
F	Food grade lubrication				Oil (lifetime lubrication)				
L	Low temperature lubrication ⁽³⁾				Oil (lifetime lubrication)				
	Installation position				Any				
S	Standard backlash	j _t	arcmin	< 3					1
R	Reduced backlash			< 5					2
	Torsional stiffness ⁽²⁾	c _g	Nm /arcmin (lb _r .in/ arcmin)	8.2 - 11.8 (73 - 104)	21.0 - 27.5 (186 - 243)	55.0 - 62.0 (487 - 549)	129.0 - 218.0 (1142 - 1929)	374.0 - 602.0 (3310 - 5328)	1
					8.2 - 13.3 (73 - 118)	21.0 - 31.0 (186 - 274)	64.0 - 81.0 (566 - 717)	127.0 - 201.0 (1124 - 1779)	365.0 - 668.0 (3231 - 5912)
	Gearbox weight ⁽²⁾	m _G	kg (lb _m)	1.4 (3.0)	3.0 (6.6)	5.0 - 5.2 (11.0 - 11.4)	11.7 - 12.0 (25.8 - 26.4)	28.5 - 29.5 (62.9 - 65.1)	1
					2.0 - 2.1 (4.4 - 4.6)	3.6 - 3.7 (7.9 - 8.0)	6.3 - 6.5 (13.9 - 14.3)	13.4 - 13.8 (29.6 - 30.5)	33.6 - 34.8 (74.0 - 76.8)
S	Standard surface				Housing: Steel – heat-treated and post-oxidized (black)				
	Running noise ⁽⁴⁾	Q _g	dB(A)	57	58	63	66	68	
	Max. bending moment based on the gearbox input flange ⁽⁵⁾	M _b	Nm (lb _r .in)	18 (159)	38 (336)	80 (708)	180 (1593)	300 (2655)	1
					18 (159)	18 (159)	38 (336)	80 (708)	180 (1593)

Output shaft loads				PSFN064	PSFN090	PSFN110	PSFN140	PSFN200	p ⁽¹⁾
Radial force for 20.000 h ⁽⁶⁾⁽⁷⁾	F _{r20.000h}	N (lb _r)		2150 (483)	3950 (888)	4900 (1102)	12000 (2698)	23000 (5171)	
Axial force for 20.000 h ⁽⁶⁾⁽⁷⁾	F _{a20.000h}			4300 (967)	8200 (1843)	9500 (2136)	8500 (1911)	16000 (3597)	
Radial force for 30.000 h ⁽⁶⁾⁽⁷⁾	F _{r30.000h}			1900 (427)	3500 (787)	4350 (978)	11000 (2473)	21000 (4721)	
Axial force for 30.000 h ⁽⁶⁾⁽⁷⁾	F _{a30.000h}			3800 (854)	7200 (1619)	8400 (1888)	7500 (1686)	14000 (3147)	
Maximum radial force ⁽⁷⁾⁽⁸⁾	F _{rStat}			2150 (483)	3950 (888)	4900 (1102)	12000 (2698)	23000 (5171)	
Maximum axial force ⁽⁷⁾⁽⁸⁾	F _{aStat}			4300 (967)	8200 (1843)	9500 (2136)	8500 (1911)	16000 (3597)	
Tilting moment for 20.000 h ⁽⁶⁾⁽⁸⁾	M _{K20.000h}	Nm (lb _r .in)		132 (1168)	326 (2885)	475 (4204)	1030 (9116)	2445 (21640)	
Tilting moment for 30.000 h ⁽⁶⁾⁽⁸⁾	M _{K30.000h}			117 (1036)	289 (2558)	422 (3735)	944 (8355)	2232 (19755)	

Moment of inertia				PSFN064	PSFN090	PSFN110	PSFN140	PSFN200	p ⁽¹⁾
Mass moment of inertia ⁽²⁾	J	kgcm ² (lb _r .in.s ² 10 ⁻⁴)		0.128 - 0.188 (1.133 - 1.664)	0.342 - 0.611 (3.027 - 5.408)	0.892 - 1.741 (7.895 - 15.409)	6.526 - 9.670 (57.760 - 85.587)	22.520 - 40.642 (199.319 - 359.712)	1
				0.124 - 0.180 (1.097 - 1.593)	0.125 - 0.197 (1.106 - 1.744)	0.325 - 0.587 (2.876 - 5.195)	0.853 - 1.836 (7.550 - 16.250)	6.434 - 10.410 (56.946 - 92.136)	2

(1) Number of stages
 (2) The ratio-dependent values can be retrieved in Tec Data Finder – www.neugart.com
 (3) T_{min} = -40°C. Optimal operating temperature max. 50°C
 (4) Sound pressure level from 1 m. measured on input running at n₁=3000 rpm no load; i=5
 (5) Max. motor weight* in kg = 0.2 x M_g / motor length in m
 * with symmetrically distributed motor weight
 * with horizontal and stationary mounting
 (6) These values are based on an output shaft speed of n₂=100 rpm
 (7) Based on the end of the output shaft
 (8) Other (sometimes higher) values following changes to T_{2N}, F_r, F_a, cycle, and service life of bearing. Application specific configuration with NCP – www.neugart.com

Output torques			PSFN064	PSFN090	PSFN110	PSFN140	PSFN200	i ⁽¹⁾	p ⁽²⁾		
Nominal output torque ⁽³⁾	T _{2N}	Nm (lb.in)	39 (345)	80 (708)	180 (1593)	470 (4160)	950 (8408)	4	1		
			40 (354)	80 (708)	175 (1549)	405 (3585)	950 (8408)	5			
			37 (327)	78 (690)	175 (1549)	355 (3142)	900 (7966)	7			
			28 (248)	59 (522)	140 (1239)	305 (2699)	750 (6638)	10			
			39 (345)	80 (708)	180 (1593)	450 (3983)	950 (8408)	16			
			39 (345)	80 (708)	180 (1593)	450 (3983)	950 (8408)	20			
					40 (354)	80 (708)	175 (1549)	405 (3585)	950 (8408)	25	2
					40 (354)	80 (708)	175 (1549)	405 (3585)	950 (8408)	35	
					39 (345)	80 (708)	180 (1593)	470 (4160)	950 (8408)	40	
					40 (354)	80 (708)	175 (1549)	405 (3585)	950 (8408)	50	
					37 (327)	78 (690)	175 (1549)	355 (3142)	900 (7966)	70	
					28 (248)	59 (522)	140 (1239)	305 (2699)	750 (6638)	100	
Max. output torque ⁽⁴⁾	T _{2max}	Nm (lb.in)	62 (549)	128 (1133)	288 (2549)	752 (6656)	1520 (13453)	4	1		
			64 (566)	128 (1133)	280 (2478)	648 (5735)	1520 (13453)	5			
			59 (522)	125 (1106)	280 (2478)	568 (5027)	1440 (12745)	7			
			45 (398)	94 (832)	224 (1983)	488 (4319)	1200 (10621)	10			
			62 (549)	128 (1133)	288 (2549)	720 (6373)	1520 (13453)	16			
			62 (549)	128 (1133)	288 (2549)	720 (6373)	1520 (13453)	20			
					64 (566)	128 (1133)	280 (2478)	648 (5735)	1520 (13453)	25	2
					64 (566)	128 (1133)	280 (2478)	648 (5735)	1520 (13453)	35	
					62 (549)	128 (1133)	288 (2549)	752 (6656)	1520 (13453)	40	
					64 (566)	128 (1133)	280 (2478)	648 (5735)	1520 (13453)	50	
					59 (522)	125 (1106)	280 (2478)	568 (5027)	1440 (12745)	70	
					45 (398)	94 (832)	224 (1983)	488 (4319)	1200 (10621)	100	

⁽¹⁾ Ratios (i=n₁/n₂)
⁽²⁾ Number of stages
⁽³⁾ Application specific configuration with NCP – www.neugart.com
⁽⁴⁾ 30.000 rotations of the output shaft permitted; see page 158

Output torques			PSFN064	PSFN090	PSFN110	PSFN140	PSFN200	i ⁽¹⁾	p ⁽²⁾
Emergency stop torque ⁽³⁾	T _{2Stop}	Nm (lb _r .in)	120 (1062)	280 (2478)	650 (5753)	1650 (14604)	3200 (28322)	4	1
			130 (1151)	280 (2478)	650 (5753)	1650 (14604)	3200 (28322)	5	
			80 (708)	175 (1549)	340 (3009)	1300 (11506)	3200 (28322)	7	
			90 (797)	200 (1770)	480 (4248)	600 (5310)	1700 (15046)	10	
			150 (1328)	300 (2655)	650 (5753)	1650 (14604)	3200 (28322)	16	
			150 (1328)	300 (2655)	650 (5753)	1650 (14604)	3200 (28322)	20	
		150 (1328)	300 (2655)	650 (5753)	1650 (14604)	3200 (28322)	25	2	
		150 (1328)	300 (2655)	650 (5753)	1650 (14604)	3200 (28322)	35		
		150 (1328)	300 (2655)	650 (5753)	1650 (14604)	3200 (28322)	40		
		150 (1328)	300 (2655)	650 (5753)	1650 (14604)	3200 (28322)	50		
		80 (708)	175 (1549)	340 (3009)	1300 (11506)	3200 (28322)	70		
		90 (797)	200 (1770)	480 (4248)	600 (5310)	1700 (15046)	100		

Input speeds			PSFN064	PSFN090	PSFN110	PSFN140	PSFN200	i ⁽¹⁾	p ⁽²⁾				
Average thermal input speed at T _{2N} and S1 ⁽⁴⁾⁽⁵⁾	n _{1N}	rpm	3200 ⁽⁶⁾	2400 ⁽⁶⁾	1800 ⁽⁶⁾	1100 ⁽⁶⁾	750 ⁽⁶⁾	4	1				
			3800 ⁽⁶⁾	2950 ⁽⁶⁾	2250 ⁽⁶⁾	1350 ⁽⁶⁾	950 ⁽⁶⁾	5					
			4500	3800 ⁽⁶⁾	2950 ⁽⁶⁾	1800 ⁽⁶⁾	1250 ⁽⁶⁾	7					
			4500	4000	3500	2300 ⁽⁶⁾	1700 ⁽⁶⁾	10					
			4500	4500	3800 ⁽⁶⁾	2450 ⁽⁶⁾	1550 ⁽⁶⁾	16	2				
			4500	4500	4000	3050 ⁽⁶⁾	1900 ⁽⁶⁾	20					
			4500	4500	4000	3350 ⁽⁶⁾	2050 ⁽⁶⁾	25					
			4500	4500	4000	3500	2650 ⁽⁶⁾	35					
			4500	4500	4000	3500	3000 ⁽⁶⁾	40					
			4500	4500	4000	3500	3000	50					
			4500	4500	4000	3500	3000	70					
			4500	4500	4000	3500	3000	100					
			Max. mechanical input speed ⁽⁴⁾	n _{1Limit}	rpm	14000	10000	8500		6500	6000		1
						14000	14000	10000		8500	6500		2

(1) Ratios (i=n₁/n₂)
 (2) Number of stages
 (3) Permitted 1000 times
 (4) Application-specific speed configurations with NCP – www.neugart.com
 (5) See page 158 for the definition
 (6) Average thermal input speed at 50% T_{2N} and S1

PSFN064
PSFN090

PSFN110

PSFN140
PSFN200

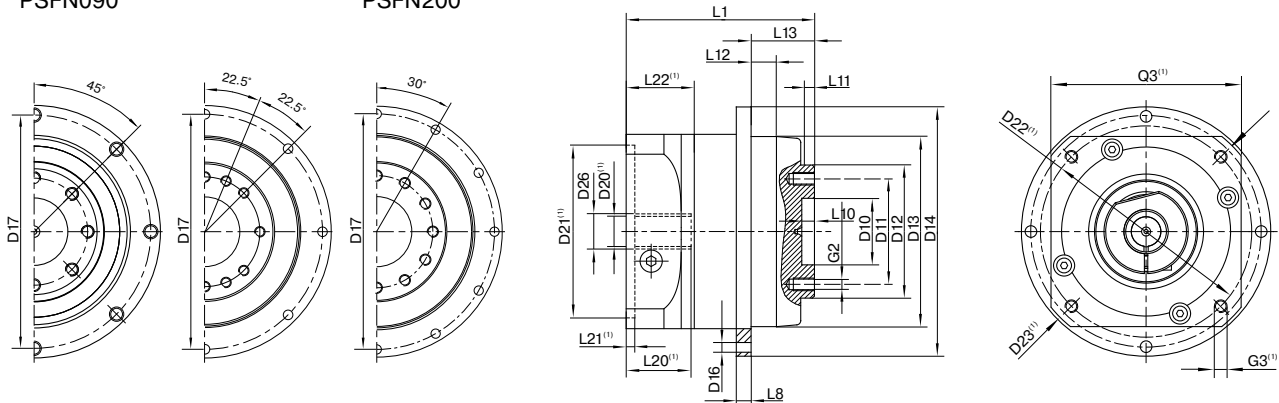

Drawing corresponds to a PSFN090 / 1-stage / flange output shaft / 14 mm clamping system / motor adaptation – 2-part – round universal flange / B5 flange type motor

⁽¹⁾The dimensions vary with the motor/gearbox flange. The input flange dimensions can be retrieved for each specific motor in Tec Data Finder at www.neugart.com

Geometry ⁽²⁾			PSFN064	PSFN090	PSFN110	PSFN140	PSFN200	p ⁽³⁾	Code
Centering diameter output shaft	D10	H7	20 (0.787)	31.5 (1.240)	40 (1.575)	50 (1.969)	80 (3.150)		
Pitch circle diameter output shaft	D11		31.5 (1.240)	50 (1.969)	63 (2.480)	80 (3.150)	125 (4.921)		
Flange output shaft diameter	D12	h7	40 (1.575)	63 (2.480)	80 (3.150)	100 (3.937)	160 (6.299)		
Centering diameter output flange	D13		64 (2.520)	90 (3.543)	110 (4.331)	140 (5.512)	200 (7.874)		
Flange diameter output	D14		86 (3.386)	118 (4.646)	145 (5.709)	179 (7.047)	247 (9.724)		
Mounting bore output	D16		4.5 8x45°	5.5 8x45°	5.5 8x45°	6.6 12x30°	9 12x30°		
Pitch circle diameter output flange	D17		79 (3.110)	109 (4.291)	135 (5.315)	168 (6.614)	233 (9.173)		
Min. total length	L1		71 (2.795)	89.5 (3.524)	108 (4.252)	142 (5.591)	172 (6.772)	1	
			99.5 (3.917)	111.5 (4.390)	130 (5.118)	173 (6.811)	217 (8.543)	2	
Flange thickness output	L8		4 (0.157)	7 (0.276)	8 (0.315)	10 (0.394)	12 (0.472)		
Centering depth output shaft	L10		4.5 (0.177)	6.5 (0.256)	6.5 (0.256)	6.5 (0.256)	10 (0.394)		
	L11		3 (0.118)	6 (0.236)	6 (0.236)	6 (0.236)	7 (0.276)		
Centering depth output flange	L12		10 (0.394)	12 (0.472)	12 (0.472)	14 (0.551)	17.5 (0.689)		
Output flange length	L13		19.5 (0.760)	30.0 (1.181)	29.0 (1.142)	38.0 (1.496)	50.0 (1.969)		
Motor shaft diameter j6/k6	D20		More information on page 155/156						
Clamping system diameter input	D26								
Flange output shaft (similar EN ISO 9409-1)									D
Number x thread x depth	G2		8 x M5x7	8 x M6x10	12 x M6x12	12 x M8x15	12 x M10x20		
Flange output shaft with dowel hole (EN ISO 9409-1)									E
Dowel hole x depth	D15	H7	5x5	6x6	6x6	8x8	10x10		
Number x thread x depth	G2		7 x M5x7	7 x M6x10	11 x M6x12	11 x M8x15	11 x M10x20		

⁽²⁾ Dimensions in mm

⁽³⁾ Number of stages