



# PLFN

The precision planetary gearbox for maximum loads and the highest performance – fast and easy to install

Our **PLFN** features a standardized flange interface for ease of installation. The straight-teeth precision planetary gearbox has been designed for the highest performance and torque. Its high tilting moment delivers the best performance even under the highest radial and axial forces.

Nominal output torque **27 - 1800 Nm**

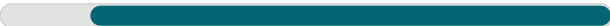

Torsional backlash **1 - 5 arcmin**



Tilting moment **132 - 4957 Nm**

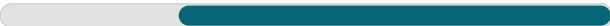

Protection class **IP65**



Frame sizes

**64**

**90**

**110**

**140**

**200**

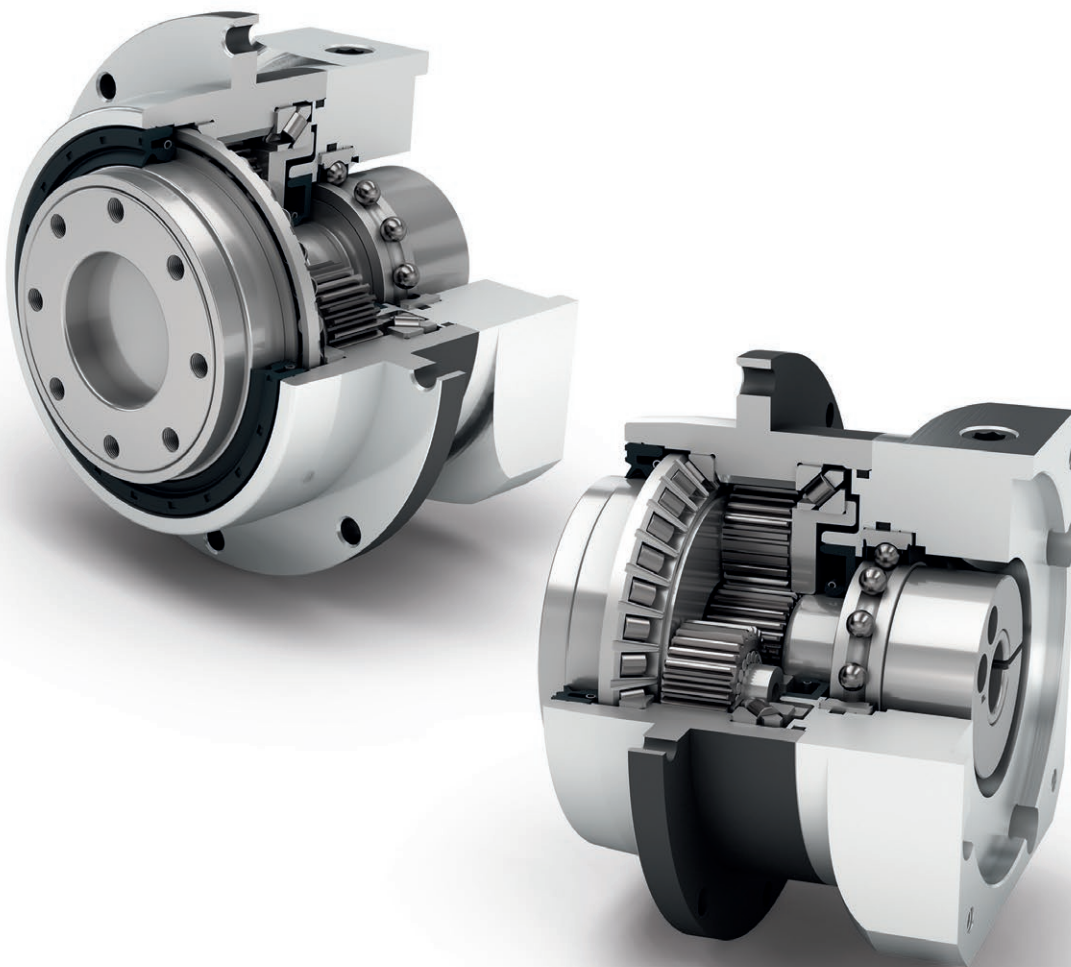

Precision Line



Equidirectional rotation

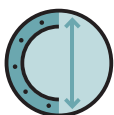

Extra large round type output flange



Rotary shaft seal



Planet carrier in cage design



Coaxial gearbox



Spur gear



Preloaded angular contact roller bearings



Flange output shaft (ISO 9409)



Option: Reduced backlash

Code	Gearbox characteristics			PLFN064	PLFN090	PLFN110	PLFN140	PLFN200	p <sup>(1)</sup>
	Service life (L <sub>10h</sub> )	t <sub>L</sub>	h	20,000					
	Service life at T <sub>2N</sub> x 0.88			30,000					
	Efficiency at full load <sup>(2)</sup>	η	%	97					1
				96					2
	Min. operating temperature	T <sub>min</sub>	°C (°F)	-25 (-13)					
	Max. operating temperature	T <sub>max</sub>		90 (194)					
	Protection class	IP65							
<b>S</b>	Standard lubrication	Oil (lifetime lubrication)							
<b>F</b>	Food grade lubrication	Oil (lifetime lubrication)							
<b>L</b>	Low temperature lubrication <sup>(3)</sup>	Oil (lifetime lubrication)							
	Installation position	Any							
<b>S</b>	Standard backlash	j <sub>t</sub>	arcmin	< 3					1
<b>R</b>	Reduced backlash			< 5					2
	Torsional stiffness <sup>(2)</sup>	c <sub>g</sub>	Nm/arcmin (lb <sub>r</sub> .in/ arcmin)	7.7 - 14.8 (68 - 131)	22.0 - 40.5 (195 - 358)	59.0 - 92.0 (522 - 814)	156.0 - 255.0 (1381 - 2257)	330.0 - 636.0 (2921 - 5629)	1
					7.6 - 14.7 (67 - 130)	18.5 - 38.0 (164 - 336)	58.0 - 91.0 (513 - 805)	177.0 - 264.0 (1567 - 2337)	391.0 - 656.0 (3461 - 5806)
	Gearbox weight	m <sub>G</sub>	kg (lb <sub>m</sub> )	1.5 (3.3)	3 (6.6)	6.5 (14.3)	13.8 (30.4)	35.5 (78.3)	1
					2.2 (4.9)	4 (8.8)	8 (17.6)	16 (35.3)	42.5 (93.7)
<b>S</b>	Standard surface	Housing: Steel – heat-treated and post-oxidized (black)							
	Running noise <sup>(4)</sup>	Q <sub>g</sub>	dB(A)	60	62	65	70	74	
	Max. bending moment based on the gearbox input flange <sup>(5)</sup>	M <sub>b</sub>	Nm (lb <sub>r</sub> .in)	18 (159)	38 (336)	80 (708)	180 (1593)	300 (2655)	1
					18 (159)	18 (159)	38 (336)	80 (708)	180 (1593)

Output shaft loads			PLFN064	PLFN090	PLFN110	PLFN140	PLFN200	p <sup>(1)</sup>
Radial force for 20,000 h <sup>(6)(7)</sup>	F <sub>r 20.000 h</sub>	N (lb <sub>r</sub> )	2150 (483)	3950 (888)	4900 (1102)	12000 (2698)	33000 (7419)	
Axial force for 20,000 h <sup>(6)(7)</sup>	F <sub>a 20.000 h</sub>		4300 (967)	8200 (1843)	9500 (2136)	8500 (1911)	15000 (3372)	
Radial force for 30,000 h <sup>(6)(7)</sup>	F <sub>r 30.000 h</sub>		1900 (427)	3500 (787)	4350 (978)	11000 (2473)	29500 (6632)	
Axial force for 30,000 h <sup>(6)(7)</sup>	F <sub>a 30.000 h</sub>		3800 (854)	7200 (1619)	8400 (1888)	7500 (1686)	13500 (3035)	
Maximum radial force <sup>(7)(8)</sup>	F <sub>r Stat</sub>		2150 (483)	3950 (888)	4900 (1102)	12000 (2698)	33000 (7419)	
Maximum axial force <sup>(7)(8)</sup>	F <sub>a Stat</sub>		4300 (967)	8200 (1843)	9500 (2136)	8500 (1911)	15000 (3372)	
Tilting moment for 20,000 h <sup>(6)(8)</sup>	M <sub>K 20.000 h</sub>	Nm (lb <sub>r</sub> .in)	132 (1168)	326 (2885)	475 (4204)	1219 (10789)	4957 (43873)	
Tilting moment for 30,000 h <sup>(6)(8)</sup>	M <sub>K 30.000 h</sub>		117 (1036)	289 (2558)	422 (3735)	1117 (9886)	4431 (39218)	

Moment of inertia			PLFN064	PLFN090	PLFN110	PLFN140	PLFN200	p <sup>(1)</sup>
Mass moment of inertia <sup>(2)</sup>	J	kgcm <sup>2</sup> (lb <sub>r</sub> .in.s <sup>2</sup> 10 <sup>-4</sup> )	0.217 - 0.288 (1.921 - 2.549)	0.580 - 0.920 (5.133 - 8.143)	2.036 - 2.942 (18.020 - 26.039)	7.313 - 12.365 (64.726 - 109.439)	26.880 - 61.170 (237.908 - 541.400)	1
			0.209 - 0.243 (1.850 - 2.151)	0.211 - 0.269 (1.868 - 2.381)	0.546 - 0.737 (4.833 - 6.523)	1.951 - 2.784 (17.268 - 24.640)	6.911 - 11.813 (61.168 - 104.554)	2

<sup>(1)</sup> Number of stages

<sup>(2)</sup> The ratio-dependent values can be retrieved in Tec Data Finder – www.neugart.com

<sup>(3)</sup> T<sub>min</sub> = -40°C. Optimal operating temperature max. 50°C

<sup>(4)</sup> Sound pressure level from 1 m, measured on input running at n<sub>1</sub>=3000 rpm no load; i=5

<sup>(5)</sup> Max. motor weight\* in kg = 0.2 x M<sub>b</sub> / motor length in m  
\* with symmetrically distributed motor weight  
\* with horizontal and stationary mounting

<sup>(6)</sup> These values are based on an output shaft speed of n<sub>2</sub>=100 rpm

<sup>(7)</sup> Based on the end of the output shaft

<sup>(8)</sup> Other (sometimes higher) values following changes to T<sub>2N</sub>, F<sub>r</sub>, F<sub>a</sub>, cycle, and service life of bearing. Application specific configuration with NCP – www.neugart.com

Output torques			PLFN064	PLFN090	PLFN110	PLFN140	PLFN200	$i^{(1)}$	$p^{(2)}$
Nominal output torque <sup>(3)</sup>	$T_{2N}$	Nm (lb <sub>r</sub> .in)	60 (531)	140 (1239)	300 (2655)	600 (5310)	1300 (11506)	4	1
			65 (575)	140 (1239)	260 (2301)	750 (6638)	1600 (14161)	5	
			45 (398)	90 (797)	180 (1593)	530 (4691)	1300 (11506)	7	
			40 (354)	80 (708)	150 (1328)	450 (3983)	1000 (8851)	8	
			27 (239)	60 (531)	125 (1106)	305 (2699)	630 (5576)	10	
			77 (682)	150 (1328)	300 (2655)	1000 (8851)	1800 (15931)	16	2
			77 (682)	150 (1328)	300 (2655)	1000 (8851)	1800 (15931)	20	
			65 (575)	140 (1239)	260 (2301)	900 (7966)	1800 (15931)	25	
			77 (682)	150 (1328)	300 (2655)	600 (5310)	1800 (15931)	32	
			65 (575)	140 (1239)	260 (2301)	750 (6638)	1800 (15931)	40	
			65 (575)	130 (1151)	260 (2301)	620 (5487)	1525 (13497)	50	
			40 (354)	80 (708)	150 (1328)	450 (3983)	1000 (8851)	64	
			27 (239)	60 (531)	125 (1106)	305 (2699)	630 (5576)	100	
			Max. output torque <sup>(4)</sup>	$T_{2max}$	Nm (lb <sub>r</sub> .in)	96 (850)	224 (1983)	480 (4248)	
104 (920)	224 (1983)	416 (3682)				1200 (10621)	2560 (22658)	5	
72 (637)	144 (1275)	288 (2549)				848 (7505)	2080 (18410)	7	
64 (566)	128 (1133)	240 (2124)				720 (6373)	1600 (14161)	8	
43 (381)	96 (850)	200 (1770)				488 (4319)	1008 (8922)	10	
123 (1089)	240 (2124)	480 (4248)				1600 (14161)	2880 (25490)	16	2
123 (1089)	240 (2124)	480 (4248)				1600 (14161)	2880 (25490)	20	
104 (920)	224 (1983)	416 (3682)				1440 (12745)	2880 (25490)	25	
123 (1089)	240 (2124)	480 (4248)				960 (8497)	2880 (25490)	32	
104 (920)	224 (1983)	416 (3682)				1200 (10621)	2880 (25490)	40	
104 (920)	208 (1841)	416 (3682)				992 (8780)	2440 (21596)	50	
64 (566)	128 (1133)	240 (2124)				720 (6373)	1600 (14161)	64	
43 (381)	96 (850)	200 (1770)				488 (4319)	1008 (8922)	100	

<sup>(1)</sup> Ratios ( $i=n_1/n_2$ )

<sup>(2)</sup> Number of stages

<sup>(3)</sup> Application specific configuration with NCP – [www.neugart.com](http://www.neugart.com)

<sup>(4)</sup> 30,000 rotations of the output shaft permitted; see page 142

Output torques			PLFN064	PLFN090	PLFN110	PLFN140	PLFN200	i <sup>(1)</sup>	p <sup>(2)</sup>
Emergency stop torque <sup>(3)</sup>	T <sub>2Stop</sub>	Nm (lb <sub>f</sub> .in)	120 (1062)	280 (2478)	650 (5753)	1300 (11506)	2700 (23897)	4	1
			130 (1151)	280 (2478)	650 (5753)	1500 (13276)	3200 (28322)	5	
			90 (797)	175 (1549)	340 (3009)	1300 (11506)	2600 (23012)	7	
			90 (797)	200 (1770)	380 (3363)	1000 (8851)	2600 (23012)	8	
			90 (797)	200 (1770)	480 (4248)	750 (6638)	1350 (11949)	10	
			150 (1328)	300 (2655)	650 (5753)	2000 (17701)	3600 (31863)	16	
		150 (1328)	300 (2655)	650 (5753)	2000 (17701)	3600 (31863)	20	2	
		150 (1328)	300 (2655)	650 (5753)	1800 (15931)	3600 (31863)	25		
		150 (1328)	300 (2655)	650 (5753)	1500 (13276)	3600 (31863)	32		
		150 (1328)	300 (2655)	650 (5753)	1500 (13276)	3600 (31863)	40		
		150 (1328)	300 (2655)	650 (5753)	1500 (13276)	3600 (31863)	50		
		80 (708)	200 (1770)	380 (3363)	1000 (8851)	2600 (23012)	64		
		80 (708)	200 (1770)	480 (4248)	750 (6638)	1350 (11949)	100		

Input speeds			PLFN064	PLFN090	PLFN110	PLFN140	PLFN200	i <sup>(1)</sup>	p <sup>(2)</sup>
Average thermal input speed at T <sub>2N</sub> and S1 <sup>(4)(5)</sup>	n <sub>1N</sub>	rpm	2100 <sup>(6)</sup>	1750 <sup>(6)</sup>	1300 <sup>(6)</sup>	850 <sup>(6)</sup>	500 <sup>(6)</sup>	4	1
			2450 <sup>(6)</sup>	2100 <sup>(6)</sup>	1650 <sup>(6)</sup>	950 <sup>(6)</sup>	600 <sup>(6)</sup>	5	
			3200 <sup>(6)</sup>	3000 <sup>(6)</sup>	2350 <sup>(6)</sup>	1400 <sup>(6)</sup>	850 <sup>(6)</sup>	7	
			3550 <sup>(6)</sup>	3350 <sup>(6)</sup>	2650 <sup>(6)</sup>	1650 <sup>(6)</sup>	1000 <sup>(6)</sup>	8	
			4100 <sup>(6)</sup>	4000 <sup>(6)</sup>	3150 <sup>(6)</sup>	2050 <sup>(6)</sup>	1300 <sup>(6)</sup>	10	
			3700 <sup>(6)</sup>	3850 <sup>(6)</sup>	3150 <sup>(6)</sup>	1700 <sup>(6)</sup>	1100 <sup>(6)</sup>	16	
			4200 <sup>(6)</sup>	4450 <sup>(6)</sup>	3750 <sup>(6)</sup>	2100 <sup>(6)</sup>	1350 <sup>(6)</sup>	20	2
			4500 <sup>(6)</sup>	4500 <sup>(6)</sup>	4000 <sup>(6)</sup>	2500 <sup>(6)</sup>	1550 <sup>(6)</sup>	25	
			4500 <sup>(6)</sup>	4500	4000	3500 <sup>(6)</sup>	2000 <sup>(6)</sup>	32	
			4500	4500	4000	3500 <sup>(6)</sup>	2250 <sup>(6)</sup>	40	
			4500	4500	4000	3500	2750 <sup>(6)</sup>	50	
			4500	4500	4000	3500	3000 <sup>(6)</sup>	64	
			4500	4500	4000	3500	3000	100	
			Max. mechanical input speed <sup>(4)</sup>	n <sub>1Limit</sub>	rpm	14000	10000	8500	
14000	14000	10000				8500	6500		2

(1) Ratios (i=n<sub>1</sub>/n<sub>2</sub>)  
 (2) Number of stages  
 (3) Permitted 1000 times  
 (4) Application-specific speed configurations with NCP – www.neugart.com  
 (5) See page 142 for the definition  
 (6) Average thermal input speed at 50% T<sub>2N</sub> and S1

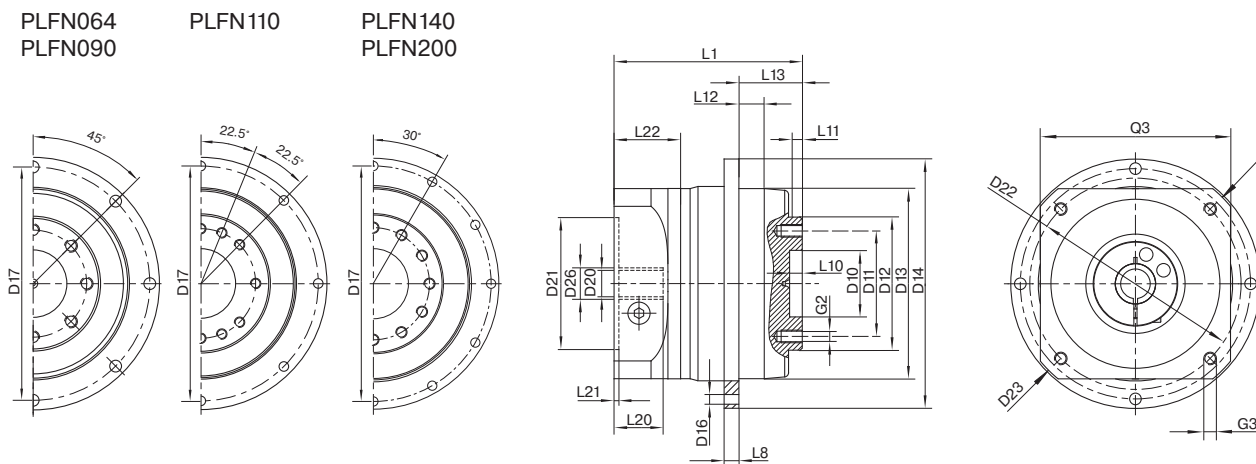

Drawing corresponds to a PLFN090 / 1-stage / flange output shaft / 19 mm clamping system / motor adaptation – 2-part – round universal flange / B5 flange type motor  
 All other variants can be retrieved in the Tec Data Finder at [www.neugart.com](http://www.neugart.com)

Geometry <sup>(1)</sup>			PLFN064	PLFN090	PLFN110	PLFN140	PLFN200	z <sup>(2)</sup>	Code	
Centering diameter output shaft	D10	H7	20 (0.787)	31.5 (1.240)	40 (1.575)	50 (1.969)	80 (3.150)			
Pitch circle diameter output shaft	D11		31.5 (1.240)	50 (1.969)	63 (2.480)	80 (3.150)	125 (4.921)			
Centering diameter output shaft	D12	h7	40 (1.575)	63 (2.480)	80 (3.150)	100 (3.937)	160 (6.299)			
Centering diameter output flange	D13		64 (2.520)	90 (3.543)	110 (4.331)	140 (5.512)	200 (7.874)			
Flange diameter output	D14		86 (3.386)	118 (4.646)	145 (5.709)	179 (7.047)	247 (9.724)			
Mounting bore output	D16		4.5 8x45°	5.5 8x45°	5.5 8x45°	6.6 12x30°	9 12x30°			
Pitch circle diameter output flange	D17		79 (3.110)	109 (4.291)	135 (5.315)	168 (6.614)	233 (9.173)			
Min. total length	L1		71 (2.795)	89 (3.504)	108 (4.252)	157 (6.181)	212.5 (8.366)	1		
			99.5 (3.917)	111 (4.370)	130 (5.118)	187.5 (7.382)	264 (10.394)	2		
Flange thickness output	L8		4 (0.157)	7 (0.276)	8 (0.315)	10 (0.394)	12 (0.472)			
Centering depth output shaft	L10		4.5 (0.177)	6.5 (0.256)	6.5 (0.256)	6.5 (0.256)	10 (0.394)			
Centering depth output shaft	L11		3 (0.118)	6 (0.236)	6 (0.236)	6 (0.236)	8 (0.315)			
Centering depth output flange	L12		10 (0.394)	12 (0.472)	12 (0.472)	14 (0.551)	17.5 (0.689)			
Output flange length	L13		19.5	30.0	29.0	38.0	50.0			
Clamping system diameter input	D26	More information on page 131								
Motor shaft diameter j6/k6	D20	The dimensions vary with the motor/gearbox flange. The input flange dimensions can be retrieved for each specific motor in Tec Data Finder at <a href="http://www.neugart.com">www.neugart.com</a>								
Max. permis. motor shaft length	L20									
Min. permis. motor shaft length										
Centering diameter input	D21									
Centering depth input	L21									
Pitch circle diameter input	D22									
Motor flange length	L22									
Diagonal dimension input	D23									
Mounting thread x depth	G3									4x
Flange cross section input	Q3									■
Flange output shaft (similar EN ISO 9409-1)									D	
Number x thread x depth	G2		8xM5x7	8xM6x10	12xM6x12	12xM8x15	12xM10x20			
Flange output shaft with dowel hole (EN ISO 9409-1)									E	
Dowel hole x depth	D15	H7	5x5	6x6	6x6	8x8	10x10			
Number x thread x depth	G2	-	7xM5x7	7xM6x10	11xM6x12	11xM8x15	11xM10x20			

<sup>(1)</sup> Dimensions in mm (in)

<sup>(2)</sup> Number of stages